

VK

VINYLESTER-STYRENE-FREE

REVISION R02.00 18.12.2020



NOTE: THIS TECHNICAL DATA SHEET REPLACES ALL PREVIOUS VERSIONS. THE INSTRUCTIONS IN THIS DOCUMENTATION ARE BASED ON OUR TESTS AND EXPERIENCE AND HAVE BEEN PREPARED TO THE BEST OF OUR KNOWLEDGE AND CONSCIENCE. DUE TO THE VARIETY OF DIFFERENT MATERIALS AND SUBSTRATES AND THE MANY DIFFERENT POSSIBLE APPLICATIONS BEYOND OUR CONTROL, WE ASSUME NO RESPONSIBILITY FOR THE RESULTS ACHIEVED. SINCE THE CONSTRUCTION AND NATURE OF THE SUBSTRATE AND THE PROCESSING CONDITIONS ARE BEYOND OUR CONTROL, WE DO NOT ACCEPT ANY LIABILITY FOR THIS PUBLICATION. IN ANY CASE, IT IS RECOMMENDED TO CARRY OUT APPROPRIATE TESTS BEFORE USE.

Content

Page

1. General	3
Product description	3
Properties and benefits	3
Applications samples	3
Handling and storage	3
Applications and intended use	4
Mortar properties	4
Reactivity	4
2. Anchorage in concrete	5
Installation instructions	5
Installation accessories	8
Setting parameter	9
Recommended loads	10
Fire resistance	13
3. Anchorage in masonry	14
Installation instructions	14
Installation parameters and accessories	17
Calculation of recommended loads	18
Recommended loads	19
4. Post-installed rebar	22
Installation instruction	22
Cleaning and installation tools	25
Design anchorage and lap length	26
Fire resistance - Overlapping joints	29
Fire resistance - Beam/wall or column/slab	32
5. Chemical resistance	39

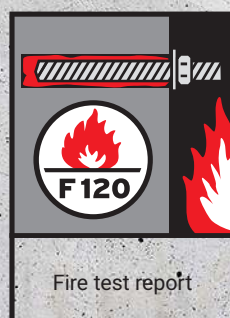
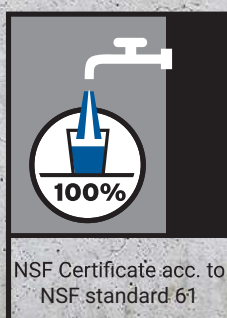

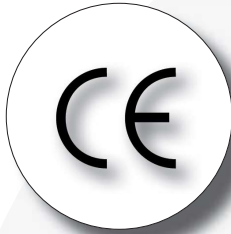

1. General

Product description

The VK mortar is a 2-component reaction resin mortar based on a vinyl ester resin styrene-free and will be delivered in a 2-c cartridge (ST - standard cartridge; SF-foil tube cartridge) system. This high performance product may be used in combination with a hand-, battery- or pneumatic tool and a static mixer. It was designed especially for the anchoring of threaded rods, reinforcing bars or internal threaded rod sleeves into concrete (also porous and light) as well as masonry. Based on the excellent standing behaviour the usability in combination with a special plastic sleeve in hollow material is given. The VK mortar product is characterised, by a huge range of applications with an installation temperature from -20°C ("Nordic" version) respectively from -10°C ("Standard" version) and an application temperature up to 120°C as well as by high chemical resistance for applications in extreme ambiances e.g. in swimming pools (chlorine) or in closeness to the sea (salt). The wide range of certificates, national and international approvals, allows nearly every application.

Properties and benefits

- European Technical Assessment for bonded fasteners acc. to EAD 330499-01-0601 (Option 1, Seismic C1 and C2): ETA-08/0237
- European Technical Assessment for injection anchors for use in masonry acc. to EAD 330076-00-0604: ETA-20/0557
- European Technical Assessment for post-installed rebar acc. to EAD 330087-00-0601: ETA-09/0277
- US-approval acc. to AC 308 in concrete (ICC-ES): ESR-2539
- ASTM C881
- Certificated for drinking water applications acc. to NSF Standard 61
- Fire resistance test report: EBB 170019_1
- For heavy anchoring - doweling and post-installed rebar connection
- Overhead application; waterfilled bore holes
- Suitable for attachment points with small edge- and axial distances due to an anchoring free of expansion forces
- High chemical resistance
- Low odour
- High bending and pressure strength
- Cartridge can be reused up to the end of the shelf life by replacing

the static mixer or resealing cartridge with the sealing cap

Applications samples

Suitable for the fixation of facades, roofs, wood constructions, metal constructions; metal profiles, columns, beams, consoles, railings, sanitary devices, cable trays, piping, post-installed rebar connection (reconstruction or reinforcement), etc.

Handling and storage

- Storage: store in a cold and dark place, storage temperature: from +5°C up to +25 °C
- Shelf life: 18 months for cartridges (ST), 12 months for foil tubes (SF)



Applications and intended use

- Base material:
cracked and non-cracked concrete, light-concrete, porous-concrete, solid masonry, hollow brick, natural stone (Attention! natural stone, can discolour; shall be checked in advance; hammer drilled bore holes, (perforated stone: rotary drilling)
- Anchor elements:
Threaded rods (zinc plated or hot dip, stainless steel and high corrosion resistance steel), reinforcing bars, internal threaded rods, profiled rod, steel section with undercuts (e.g. perforated section)
- Temperature range:
-20°C (-10°C) up to +40°C installation temperature
cartridge temperature min. +5°C; optimal +20°C,
base material temperature after full curing -40°C to +120°C

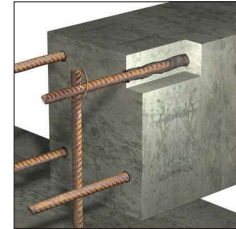

Mortar properties

Properties	Test Method	Result
UV resistance	-	Pass
Watertightness	DIN EN 12390-8	0 mm
Temperature stability	-	120 °C
pH-value	-	> 12
Density	-	1,77 kg / dm ³
Compressive strength	EN 196 Teil1	100 N / mm ²
Flexural strength	EN 196 Teil1	15 N / mm ²
E modulus	EN 12504-4	14000 N / mm ²
Shrinkage	-	< 0,3 %
Hardness Shore D	-	90
Electrical resistance	IEC 93	3,6 10 ⁹ W m
Thermal conductivity	IEC 60093	0,65 W/m·K

Reactivity

Temperature of base material	VK-Standard	
	Gelling- and working time	Full curing time in dry base material ¹⁾
-10 °C to -6°C	90 min ^{2) 3)}	24 h ^{2) 3)}
-5 °C to -1°C	90 min ²⁾	14 h ²⁾
0 °C to +4°C	45 min	7 h
+5 °C to +9°C	25 min	2 h
+ 10 °C to +19°C	15 min	80 min
+ 20 °C to +29°C	6 min	45 min
+ 30 °C to +34°C	4 min	25 min
+ 35 °C to +39°C	2 min	20 min
+40°C	1,5 min	15 min
Cartridge temperature	+5 °C to +40 °C	

¹⁾ The curing times in wet concrete has to be doubled.

²⁾ The application is not permitted in masonry.

³⁾ The cartridge temperature must be conditioned to min. +15°C.



Temperature of base material	VK Nordic	
	Gelling- and working time	Full curing time in dry base material ¹⁾
-20 °C to -16 °C	75 min ²⁾	24 h ²⁾
-15 °C to -11 °C	55 min ²⁾	16 h ²⁾
-10 °C to -6 °C	35 min ²⁾	10 h ²⁾
-5 °C to -1 °C	20 min ²⁾	5 h ²⁾
0 °C to +4 °C	10 min	2,5 h
+5 °C to +9 °C	6 min	80 min
+ 10 °C	6 min	60 min
cartridge temperature	-20 °C to +10 °C	

¹⁾ The curing times in wet concrete has to be doubled.

²⁾ The application is not permitted in masonry.

2. Anchorage in concrete

Installation instructions

Drilling of the bore hole	
	<p>1a. Drill with hammer drill (HD) a hole into the base material to the size and embedment depth required by the selected anchor (see page 8), with hammer (HD), hollow (HDB) or compressed air (CD) drilling. The use of a hollow drill bit is only in combination with a sufficient vacuum permitted. In case of aborted drill hole: the drill hole shall be filled with mortar</p>
<p>Attention! Standing water must be removed before cleaning.</p>	
<p>MAC: Cleaning for nominal drill hole diameter $d_0 \leq 20\text{mm}$ and drill depth $h_0 \leq 10d_{\text{nom}}$ (only un-cracked concrete!)</p>	
	<p>2a. Starting from the bottom or back of the bore hole, blow the hole clean with a hand pump (see page 8) a minimum of four times.</p>
	<p>2b. Check brush diameter (see page 8) Brush the hole with an appropriate sized wire brush $> d_{b,\text{min}}$ (see page 8) a minimum of four times in a twisting motion. If the bore hole ground is not reached with the brush, a brush extension must be used.</p>
	<p>2c. Finally blow the hole clean again with a hand pump (see page 8) a minimum of four times.</p>



CAC: Cleaning for all drill hole diameter in uncracked and cracked concrete	
	<p>2a. Starting from the bottom or back of the bore hole, blow the hole clean with compressed air (min. 6 bar) (see page 8) a minimum of four times until return air stream is free of noticeable dust. If the bore hole ground is not reached an extension must be used.</p>
	<p>2b. Check brush diameter (see page 8). Brush the hole with an appropriate sized wire brush $> d_{b,min}$ (see page 8) a minimum of four times in a twisting motion. If the bore hole ground is not reached with the brush, a brush extension must be used.</p>
	<p>2c. Finally blow the hole clean again with compressed air (min. 6 bar) (see page 8) a minimum of four times until return air stream is free of noticeable dust. If the bore hole ground is not reached an extension must be used.</p>
<p>After cleaning, the bore hole has to be protected against re-contamination in an appropriate way, until dispensing the mortar in the bore hole. If necessary, the cleaning has to be repeated directly before dispensing the mortar. In-flowing water must not contaminate the bore hole again.</p>	
	<p>3. Attach a supplied static-mixing nozzle to the cartridge and load the cartridge into the correct dispensing tool. After every working interruption longer than the recommended working time (see page 4 - 5) as well as for new cartridges, a new static-mixer shall be used.</p>
	<p>4. Prior to inserting the anchor rod into the filled bore hole, the position of the embedment depth shall be marked on the anchor rods.</p>
	<p>5. Prior to dispensing into the anchor hole, squeeze out separately a minimum of three full strokes and discard non-uniformly mixed adhesive components until the mortar shows a consistent grey colour. For foil tube cartridges it must be discarded a minimum of six full strokes.</p>
	<p>6. Starting from the bottom resp. back of the cleaned anchor hole fill the hole up to approximately two-thirds with adhesive. Slowly withdraw of the static mixing nozzle as the hole is filled avoids creating air pockets. If the bore hole ground is not reached with the static-mixing nozzle, a appropriate extension must be used. Observe the gel-/ working times given (see page 4 - 5).</p>
	<p>7. Piston plugs and mixer nozzle extensions shall be used according to table page 8 for the following applications:</p> <ul style="list-style-type: none"> • Horizontal assembly (horizontal direction) and ground erection (vertical downwards direction): Drill bit-$\varnothing d_0 \geq 18$ mm and embedment depth $h_{ef} > 250$mm • Overhead assembly (vertical upwards direction): Drill bit-$\varnothing d_0 \geq 18$ mm



	<p>8. Push the threaded rod or reinforcing bar into the anchor hole while turning slightly to ensure positive distribution of the adhesive until the embedment depth is reached.</p> <p>The anchor should be free of dirt, grease, oil or other foreign material.</p>
	<p>9. Be sure that the anchor is fully seated at the bottom of the hole and that excess mortar is visible at the top of the hole. If these requirements are not maintained, the application has to be renewed.</p> <p>For overhead application the anchor rod shall be fixed (e. g. wedges).</p>
	<p>10. Allow the adhesive to cure to the specified time prior to applying any load or torque. Do not move or load the anchor until it is fully cured (see page 4 - 5).</p>
	<p>11. After full curing, the add-on part can be installed with up to the max. torque (see page 9) by using a calibrated torque wrench. It can be optional filled the annular gap between anchor and fixture with mortar. Therefor substitute the washer by the filling washer and connect the mixer reduction nozzle to the tip of the mixer. The annular gap is filled with mortar, when mortar oozes out of the washer.</p>



Installation accessories

CAC - Rec. compressed air tool (min 6 bar)
 Drill bit diameter (d_0): 10 mm to 28 mm



MAC - Hand pump (volume 750 ml)
 Drill bit diameter (d_0): 10 mm to 20 mm or drill
 hole depth up to 240 mm







Steel brush RBT and brush extension

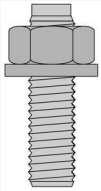
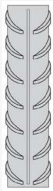

SDS Plus Adapter

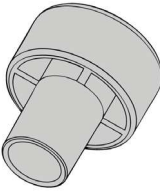

										
Threaded rod	Rebar	Internal threaded Anchor rod	d_0 Drill bit - Ø HD	d_b Brush-Ø		$d_{b,min}$ min. Brush-Ø	Piston plug	Installation direction and use of piston plug		
[mm]	[mm]	[mm]	[mm]	[-]	[mm]	[mm]	[-]	↓	→	↑
M 8	-	-	10	RBT 10	12	10,5	No piston plug required			
M 10	8	IG-M6	12	RBT 12	14	12,5				
M 12	10	IG-M8	14	RBT 14	16	14,5				
-	12	-	16	RBT 16	18	16,5				
M 16	14	IG-M10	18	RBT 18	20	18,5	VS 18	$h_{ef} > 250$ mm	$h_{ef} > 250$ mm	all
-	16	-	20	RBT 20	22	20,5	VS 20			
M 20	20	IG-M12	24	RBT 24	26	24,5	VS 24			
M 24	-	IG-M16	28	RBT 28	30	28,5	VS 28			
M 27	25	-	32	RBT 32	34	32,5	VS 32			
M 30	28	IG-M20	35	RBT 35	37	35,5	VS 35			
-	32	-	40	RBT 40	41,5	40,5	VS 40			



Setting parameter

Anchor size			M8	M10	M12	M16	M20	M24	M27	M30
Outer diameter of anchor	$d = d_{nom}$	[mm]	8	10	12	16	20	24	27	30
Nominal drill hole diameter	d_0	[mm]	10	12	14	18	24	28	32	35
Effective embedment depth	$h_{ef,min}$	[mm]	60	60	70	80	90	96	108	120
	$h_{ef,max}$	[mm]	160	200	240	320	400	480	540	600
Diameter of clearance hole in the fixture	$d_f \leq$	[mm]	9	12	14	18	22	26	30	33
Maximum torque moment	$T_{inst} \leq$	[Nm]	10	20	40	80	120	160	180	200
Minimum thickness of member	h_{min}	[mm]	$h_{ef} + 30 \text{ mm} \geq 100 \text{ mm}$			$h_{ef} + 2d_0$				
Minimum spacing	S_{min}	[mm]	40	50	60	80	100	120	135	150
Minimum edge distance	C_{min}	[mm]	40	50	60	80	100	120	135	150

Rebar size			ø8	ø10	ø12	ø14	ø16	ø20	ø25	ø28	ø32
Outer diameter of anchor	$d = d_{nom}$	[mm]	8	10	12	14	16	20	25	28	32
Nominal drill hole diameter	d_0	[mm]	12	14	16	18	20	24	32	35	40
Effective embedment depth	$h_{ef,min}$	[mm]	60	60	70	75	80	90	100	112	128
	$h_{ef,max}$	[mm]	160	200	240	280	320	400	500	580	640
Minimum thickness of member	h_{min}	[mm]	$h_{ef} + 30 \text{ mm} \geq 100 \text{ mm}$			$h_{ef} + 2d_0$					
Minimum spacing	S_{min}	[mm]	40	50	60	70	80	100	125	140	160
Minimum edge distance	C_{min}	[mm]	40	50	60	70	80	100	125	140	160

Size internal threaded anchor rod			IG-M6	IG-M8	IG-M10	IG-M12	IG-M16	IG-M20
Internal diameter of anchor	d_2	[mm]	6	8	10	12	16	20
Outer diameter of anchor ¹⁾	$d = d_{nom}$	[mm]	10	12	16	20	24	30
Nominal drill hole diameter	d_0	[mm]	12	14	18	22	28	35
Effective embedment depth	$h_{ef,min}$	[mm]	60	70	80	90	96	120
	$h_{ef,max}$	[mm]	200	240	320	400	480	600
Diameter of clearance hole in the fixture	d_f	[mm]	7	9	12	14	18	22
Maximum torque moment	T_{min}	[Nm]	10	10	20	40	60	100
Thread engagement length (min/max)	l_G	[mm]	8/20	8/20	10/25	12/30	16/32	20/40
Minimum thickness of member	h_{min}	[mm]	$h_{ef} + 30 \text{ mm} \geq 100 \text{ mm}$			$h_{ef} + 2d_0$		
Minimum spacing	s_{min}	[mm]	50	60	80	100	120	150
Minimum edge distance	c_{min}	[mm]	50	60	80	100	120	150

¹⁾ With metric threads according to EN 1993-1-8:2005+AC:2009



Recommended loads

Threaded rod

The recommended loads are only valid for single anchors for a roughly design, if the following conditions are valid:

- $c \geq 1,5 \times h_{ef}$ $s \geq 3,0 \times h_{ef}$ $h \geq 2 \times h_{ef}$
- $\psi_{sus} = 1,0$; percentage of dead load $\leq \psi_{sus}^0$ see table below
- The recommended loads have been calculated using the partial safety factors for resistances stated in ETA(s) and with a partial safety factor for actions of $\gamma_f=1.4$.
The partial safety factor for seismic action is $\gamma_1 = 1,0$.

If the conditions are not fulfilled the loads must be calculated acc. to EN 1992-4.

For further details observe ETA-08/0237.

<ul style="list-style-type: none"> • Property class 5.8 • Concrete - C20/25 • Hammer drilling (HD, CD, HDB) • dry, wet concrete 				M8	M10	M12	M16	M20	M24	M27	M30
Recommended tension load	40°C / 24°C ¹⁾ $\psi_{sus}^0 = 0,73$	uncracked	$N_{rec,stat}$ [kN]	8,6	13,5	19,7	27,3	43,3	59,4	77,2	86,6
		cracked	$N_{rec,stat}$ [kN]	3,8	5,6	9,1	13,7	23,3	34,6	54,0	60,6
	$N_{rec,eq,C1}$ [kN]		3,4	4,9	8,5	12,9	22,0	33,4	53,0	60,6	
	80°C / 50°C ¹⁾ $\psi_{sus}^0 = 0,65$	uncracked	$N_{rec,stat}$ [kN]	7,2	10,1	14,8	22,4	38,1	53,4	63,1	65,6
		cracked	$N_{rec,stat}$ [kN]	2,4	3,9	6,6	10,0	17,0	25,1	37,9	45,4
	$N_{rec,eq,C1}$ [kN]		2,1	3,5	6,2	9,4	16,0	24,6	36,5	43,8	
120°C/72°C ¹⁾ $\psi_{sus}^0 = 0,57$	uncracked	$N_{rec,stat}$ [kN]	5,3	7,3	10,7	16,2	27,6	40,8	46,3	50,5	
	cracked	$N_{rec,stat}$ [kN]	1,9	2,8	4,9	7,5	12,7	18,8	29,5	35,3	
$N_{rec,eq,C1}$ [kN]		1,7	2,5	4,6	7,0	11,9	18,5	28,3	33,9		
Recommended shear load without lever arm ^{2) 3)}	uncracked	$V_{rec,stat}$ [kN]	6,3	9,7	14,3	20,8	34,1	48,1	63,5	72,3	
		$V_{rec,stat}$ [kN]	3,8	6,7	11,7	14,8	24,2	34,0	45,0	51,2	
	cracked	$V_{rec,eq,C1}$ [kN]	3,0	5,1	9,4	14,2	24,2	34,0	45,0	51,2	
Embedment depth	h_{ef} [mm]	80	90	110	125	170	210	250	270		
Edge distance	$c \geq$ [mm]	120	135	165	187,5	255	315	375	405		
Axial distance	$s \geq$ [mm]	240	270	330	375	510	630	750	810		

¹⁾ Short term temperature/ Long term temperature.

²⁾ Shear loads are valid for all specified temperature ranges.

³⁾ In case of seismic action, the annular gap between the anchor rod and the through hole of the attachment must be filled with mortar, otherwise $\alpha_{gap} = 0,5$ acc. to ETA-08/0237 must be taken into account.

$N_{rec,stat}$ $V_{rec,stat}$ = Recommended load under static and quasi-static action

$N_{rec,eq}$ $V_{rec,eq}$ = Recommended load under seismic action



Internal threaded rod

The recommended loads are only valid for single anchors for a roughly design, if the following conditions are valid:

- $c \geq 1,5 \times h_{ef}$ $s \geq 3,0 \times h_{ef}$ $h \geq 2 \times h_{ef}$
- $\psi_{SUS} = 1,0$; percentage of dead load $\leq \psi_{SUS}^0$ see table below
- The recommended loads have been calculated using the partial safety factors for resistances stated in ETA(s) and with a partial safety factor for actions of $\gamma_f=1.4$. The partial safety factor for seismic action is $\gamma_f = 1,0$.

If the conditions are not fulfilled the loads must be calculated acc. to EN 1992-4. For further details observe ETA-08/0237.

<ul style="list-style-type: none"> • Property class 5.8 • Concrete - C20/25 • Hammer drilling (HD, CD, HDB) • dry, wet concrete 				IG-M6	IG-M8	IG-M10	IG-M12	IG-M16	IG-M20
Recommended tension load	40°C / 24°C ¹⁾ $\psi_{SUS}^0 = 0,73$	uncracked	$N_{rec,stat}$ [kN]	4,8	8,1	13,8	20,0	36,2	58,6
		cracked	$N_{rec,stat}$ [kN]	4,8	8,1	13,7	20,0	34,6	58,6
	80°C / 50°C ¹⁾ $\psi_{SUS}^0 = 0,65$	uncracked	$N_{rec,stat}$ [kN]	4,8	8,1	13,8	20,0	36,2	58,6
		cracked	$N_{rec,stat}$ [kN]	4,7	6,6	10,0	17,0	25,1	47,1
	120°C/72°C ¹⁾ $\psi_{SUS}^0 = 0,57$	uncracked	$N_{rec,stat}$ [kN]	4,8	8,1	13,8	20,0	36,2	52,4
		cracked	$N_{rec,stat}$ [kN]	3,4	4,9	7,5	12,7	18,8	36,7
Recommended shear load without lever arm ^{2) 3)}	uncracked	$V_{rec,stat}$ [kN]	3,4	5,7	9,7	14,3	26,3	42,3	
	cracked	$V_{rec,stat}$ [kN]	3,4	5,7	9,7	14,3	26,3	42,3	
Embedment depth		h_{ef} [mm]	90	110	125	170	210	280	
Edge distance		$c \geq$ [mm]	165	188	255	315	420	420	
Axial distance		$s \geq$ [mm]	330	375	510	630	840	840	

¹⁾ Short term temperature/ Long term temperature.

²⁾ Shear loads are valid for all specified temperature ranges.

³⁾ In case of seismic action, the annular gap between the anchor rod and the through hole of the attachment must be filled with mortar, otherwise $\alpha_{gap} = 0,5$ acc. to ETA-08/0237 must be taken into account.

$N_{rec,stat}$ $V_{rec,stat}$ = Recommended load under static and quasi-static action

$N_{rec,eq}$ $V_{rec,eq}$ = Recommended load under seismic action



Rebar

The recommended loads are only valid for single anchors for a roughly design, if the following conditions are valid:

- $c \geq 1,5 \times h_{ef}$ $s \geq 3,0 \times h_{ef}$ $h \geq 2 \times h_{ef}$
- $\psi_{sus} = 1,0$; percentage of dead load $\leq \psi_{sus}^0$ see table below
- The recommended loads have been calculated using the partial safety factors for resistances stated in ETA(s) and with a partial safety factor for actions of $\gamma_f=1.4$.
The partial safety factor for seismic action is $\gamma_f = 1,0$.

If the conditions are not fulfilled the loads must be calculated acc. to EN 1992-4.
For further details observe ETA-09/0277.

<ul style="list-style-type: none"> • Property class BSt 500 • Concrete - C20/25 • Hammer drilling (HD) • dry, wet concrete 					ø8	ø10	ø12	ø14	ø16	ø20	ø25	ø28	ø32
Recommended tension load	40°C / 24°C ¹⁾ $\psi_{sus}^0 = 0,73$	uncracked	$N_{rec,stat}$ [kN]	9,6	13,5	19,7	24,1	27,3	43,3	59,4	77,2	86,6	
		cracked	$N_{rec,stat}$ [kN]	3,8	5,6	9,1	11,0	13,7	23,3	36,0	54,0	60,6	
			$N_{rec,eq,C1}$ [kN]	3,4	4,9	8,5	10,4	12,9	22,0	34,8	55,0	67,9	
	80°C / 50°C ¹⁾ $\psi_{sus}^0 = 0,65$	uncracked	$N_{rec,stat}$ [kN]	7,2	10,1	14,8	18,1	22,4	38,1	52,4	61,1	64,6	
		cracked	$N_{rec,stat}$ [kN]	2,4	3,9	6,6	8,0	10,0	17,0	26,2	39,3	48,5	
			$N_{rec,eq,C1}$ [kN]	2,1	3,5	6,2	7,6	9,4	16,0	25,7	37,9	46,7	
	120°C/72°C ¹⁾ $\psi_{sus}^0 = 0,57$	uncracked	$N_{rec,stat}$ [kN]	5,3	7,3	10,7	13,0	16,2	27,6	39,3	43,6	48,7	
		cracked	$N_{rec,stat}$ [kN]	1,9	2,8	4,9	6,0	7,5	12,7	19,6	30,5	37,7	
			$N_{rec,eq,C1}$ [kN]	1,7	2,5	4,6	5,6	7,0	11,9	19,2	29,3	36,2	
	Recommended shear load without lever arm ^{2) 3)}	uncracked	$V_{rec,stat}$ [kN]	6,7	10,5	14,8	18,0	20,8	34,1	48,4	63,8	73,0	
			$V_{rec,stat}$ [kN]	3,8	6,7	11,7	12,8	14,8	24,2	34,3	45,2	51,7	
		cracked	$V_{rec,eq,C1}$ [kN]	3,0	5,1	9,4	11,5	14,2	24,2	34,3	45,2	51,7	
Embedment depth	h_{ef} [mm]		80	90	110	115	125	170	210	250	270		
Edge distance	$c \geq$ [mm]		120	135	165	172,5	187,5	255	315	375	405		
Axial distance	$s \geq$ [mm]		240	270	330	345	375	510	630	750	810		

¹⁾ Short term temperature/ Long term temperature.

²⁾ Shear loads are valid for all specified temperature ranges.

³⁾ In case of seismic action, the annular gap between the anchor rod and the through hole of the attachment must be filled with mortar, otherwise $\alpha_{gap} = 0,5$ acc. to ETA-08/0237 must be taken into account.

$N_{rec,stat}$ $V_{rec,stat}$ = Recommended load under static and quasi-static action

$N_{rec,eq}$ $V_{rec,eq}$ = Recommended load under seismic action



Fire resistance

The present recommended loads of fire resistance is assessed with respect to its fire resistance properties as anchor applications in walls and ceilings. The evaluation is based on tests according to DIN EN 1363-1:2012 and Technical Report 020.

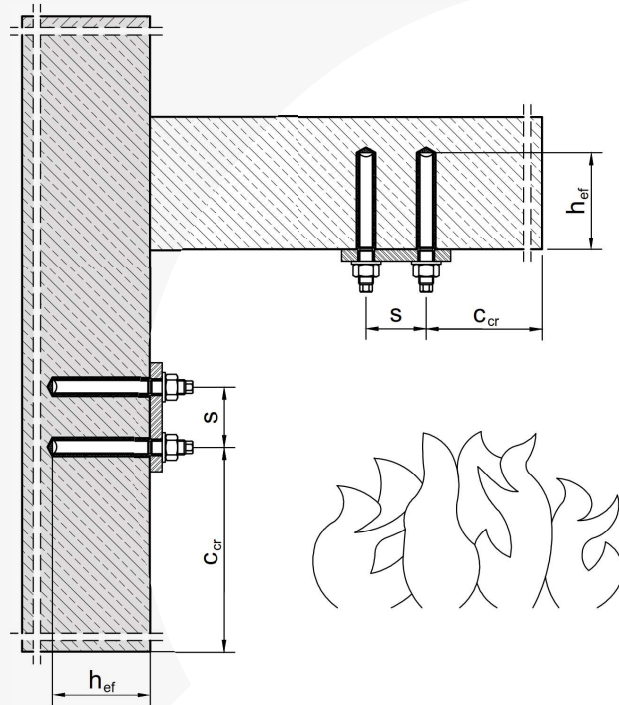

The recommended tension and shear loads under fire exposure of the following table are only valid if the following conditions are met:

- uncracked concrete: Property class min. C20/25
- $c \geq 2,0 \times h_{ef}$
- $s \geq 4,0 \times h_{ef}$
- Threaded rod zinc plated: Property class min. 5.8 (EN 1993-1-8:2005+AC:2009)
- Threaded rod made of stainless steel and high corrosion resistance steel: Property class min. 70 (EN ISO 3506-1:2009)

The recommended loads have been calculated using the partial safety factor for resistances under fire exposure of $\gamma_{M,fi} = 1.0$ and with a partial safety factor for actions of $\gamma_f = 1.0$.

Anchor size	h_{ef} [mm]	Fire resistance time in minutes			
		R30 max F [kN]	R60 max F [kN]	R90 max F [kN]	R120 max F [kN]
M8	≥ 80	1,6	1,1	0,6	0,3
M10	≥ 90	2,6	1,8	0,9	0,5
M12	≥ 110	3,4	2,6	1,8	1,4
M16	≥ 125	6,2	4,8	3,4	2,7
M20	≥ 170	9,8	7,5	5,3	4,2
M24	≥ 210	14,0	10,8	7,6	6,0
M27	≥ 250	18,3	4,1	9,9	7,9
M30	≥ 280	22,3	17,2	12,1	9,6



3. Anchorage in masonry

Installation instructions

Preparation of cartridge

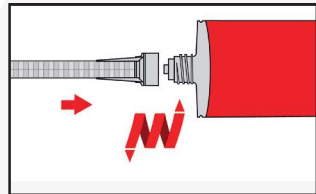

1. Remove the cap and attach the supplied static-mixing nozzle to the cartridge and load the cartridge into the correct dispensing tool. In case of a foil tube cartridge, cut off the clip before use. For every working interruption longer than the recommended working time (see page 4 - 5) as well as for new cartridges, a new static-mixer shall be used.

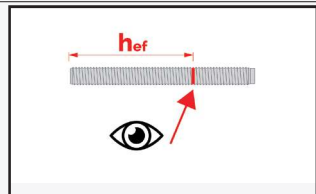

2. Prior to inserting the anchor rod into the filled bore hole, the position of the embedding depth shall be marked on the anchor rods.

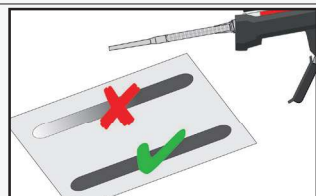

3. Prior to dispensing into the anchor hole, squeeze out separately a minimum of three full strokes and discard non-uniformly mixed adhesive components until the mortar shows a consistent grey colour. For foil tube cartridges it must be discarded a minimum of six full strokes



Installation in solid masonry (without sleeve)	
	<p>4. Holes to be drilled perpendicular to the surface of the base material by using a hard-metal tipped hammer drill bit. Drill a hole, with drilling method according to page 17, into the base material, with nominal drill hole diameter and bore hole depth according to the size and embedment depth required by the selected anchor. In case of aborted drill hole the drill hole shall be filled with mortar.</p>
	<p>5a. Starting from the bottom or back of the bore hole, blow the hole clean with handpump (see page 17) a minimum of two times.</p>
	<p>5b. Attach an appropriate sized wire brush $> d_{b,min}$ (see page 17) to a drill or a cordless screwdriver and brush the hole clean with a minimum of two times in a twisting motion. If the bore hole ground is not reached with the brush, a brush extension must be used.</p>
	<p>5c. Finally blow the hole clean again with handpump (see page 17) a minimum of two times.</p>
	<p>6. Starting from the bottom resp. back of the cleaned anchor hole fill the hole up to approximately two-thirds with adhesive. Slowly withdraw of the static mixing nozzle as the hole is filled avoids creating air pockets. Observe the gel-/ working times given (see page 4 - 5).</p>
	<p>7. Push the threaded rod or reinforcing bar into the anchor hole while turning slightly to ensure positive distribution of the adhesive until the embedment depth is reached.</p> <p>The anchor should be free of dirt, grease, oil or other foreign material.</p>
	<p>8. Be sure that the anchor is fully seated at the bottom of the hole and that excess mortar is visible at the top of the hole. If these requirements are not maintained, the application has to be renewed.</p> <p>For overhead application the anchor rod shall be fixed (e. g. wedges)..</p>
	<p>9. Allow the adhesive to cure to the specified time prior to applying any load or torque. Do not move or load the anchor until it is fully cured. (see page 4 - 5).</p>
	<p>10. After full curing, the fixture can be installed with up to the max. installation torque (see page 17) by using a calibrated torque wrench.</p>



	<p>4. Holes to be drilled perpendicular to the surface of the base material by using a hard-metal tipped hammer drill bit. Drill a hole, with drill method according to page 17 – 21, into the base material, with nominal drill hole diameter and bore hole depth according to the size and embedment depth required by the selected anchor.</p>
	<p>5a. Starting from the bottom or back of the bore hole, blow the hole clean with handpump (see page 17) a minimum of two times.</p>
	<p>5b. Attach an appropriate sized wire brush $> d_{b,min}$ (see page 17) to a drill or a cordless screwdriver and brush the hole clean with a minimum of two times in a twisting motion. If the bore hole ground is not reached with the brush, a brush extension must be used.</p>
	<p>5c. Finally blow the hole clean again with handpump (see page 17) a minimum of two times.</p>
	<p>6. Insert the perforated sleeve flush with the surface of the masonry or plaster. Only use sleeves that have the right length. Never cut the sleeve. For installation through insulation the sleeve SH 16x130/330 shall be cutted at the top end according to the insulation thickness.</p>
	<p>7. Starting from the bottom or back fill the sleeve with adhesive. For embedment depth equal to or larger than 130 mm an extension nozzle shall be used. For quantity of mortar attend cartridges label installation instructions. For push through installation the sleeve within the fixture must also be fully filled with mortar. Observe the gel-/working times given in the tables on page 4 - 5)</p>
	<p>8. Push the threaded rod into the anchor hole while turning slightly to ensure positive distribution of the adhesive until the embedment depth is reached. The anchor shall be free of dirt, grease, oil or other foreign material.</p>
	<p>9. Allow the adhesive to cure to the specified curing time prior to applying any load or torque. Do not move or load the anchor until it is fully cured (attend tables on page 4 - 5).</p>
	<p>10. After full curing, the fixture can be installed with up to the max. installation torque (See parameters of brick on page 17) by using a calibrated torque wrench.</p>



Installation parameters and accessories

Solid brick and autoclaved aerated concrete			M8	M10	IG-M6	M12	IG-M8	M16	IG-M10
Nominal drill hole diameter	d_0	[mm]	10	12		14		18	
Effective anchorage depth	h_{ef}	[mm]	80	90		100		100	
Drill hole depth	h_0	[mm]	80	90		100		100	
Minimum wall thickness	h_{min}	[mm]	$h_{ef} + 30$						
Diameter of clearance hole in the fixture	d_f	[mm]	9	12	7	14	9	18	12
Diameter of steel brush	$d_b \geq$	[mm]	RBT10	RBT12		RBT14		RBT18	
Min. brush diameter	$d_{b,min}$	[mm]	10,5	12,5		14,5		18,5	
Max. installation torque	$T_{inst,max}$	[Nm]	see tables on page 19-21						

Hollow brick and solid brick with sleeve			M8	M8/M10/IG-M6		M12 /M16/IG-M8/ IG-M10		
Perforated sleeve			SH12x80	SH16x85	SH16x130 ¹⁾	SH20x85	SH20x130	SH20x200
Nominal drill hole diameter	d_0	[mm]	12	16	16	20	20	20
Effective anchorage depth	h_{ef}	[mm]	80	85	130	85	130	200
Drill hole depth	h_0	[mm]	85	90	135	90	135	205
Minimum wall thickness	h_{min}	[mm]	115	115	175	115	175	240
Diameter of clearance hole in the fixture	d_f	[mm]	9	7 (IG-M6) / 9 (M8) / 12 (M10)		9 (IG-M8) / 12 (IG-M10) / 14 (M12) / 18 (M16)		
Diameter of steel brush	$d_b \geq$	[mm]	RBT12	RBT16		RBT20		
Min. brush diameter	$d_{b,min}$	[mm]	12,5	16,5		20,5		
Max. installation torque	$T_{inst,max}$	[Nm]	see tables on page 19-21					

¹⁾ The data also apply to the SH16x130/330 perforated sleeve

Steel brush RBT and brush extension



Hand pump (volume 750 ml)



SDS Plus Adapter





Calculation of recommended loads

The recommended loads given are for preliminary planning purposes only and do not replace dimensioning.

The following conditions must be met:

- Dry environment
- Temperature range 24/40°C (long-term/short-term)
- Spacing distance $s \geq s_{cr}$
- Edge distance $c \geq c_{cr}$
- Strength class of masonry mortar at least M2.5
- Brick strength as well as density and dimensions
- Joints are visible
- Vertical joint is mortared
- Strength class of the threaded rod is min. 5.8 oder higher
- Drilling method:
 "rotary drilling" in hollow brick and autoclaved aerated concrete (AAC),
 "hammer drilling" in solid brick

The recommended loads take into account all partial safety factors (resistance 2.5; action 1.4) and all failure modes. An interaction between tension and transverse tension was not taken into account.

If one or more of the conditions listed above are not fulfilled, the application must be recalculated according to TR054 and the requirements of the relevant ETA.

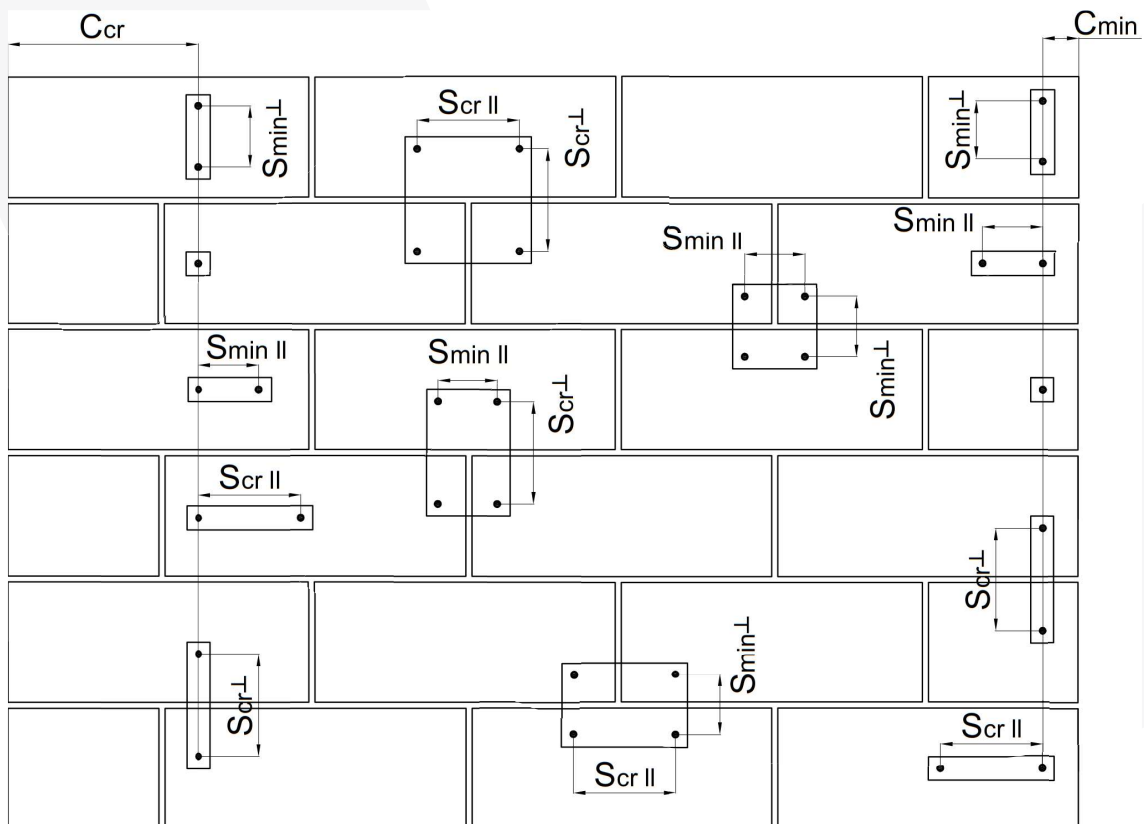









Recommended loads

Naming Compressive strength Density Dimensions	Picture	Anchor rods	Perforated sleeve	T_{inst}	C_{cr}	C_{min}	S_{cr}	S_{min}	N_{rec}	V_{rec}
				[Nm]	[mm]	[mm]	[mm]	[mm]	[kN]	[kN]
Calcium silica solid bricks acc. to EN 771-2										
Solid limestone KS 20 N/mm ² $\rho \geq 2,0 \text{ kg/dm}^3$ $\geq 240 \times 115 \times 71 \text{ mm}$		M8 to M16 IG-M6 to IG-M10	without 12x80 16x85; 16x130 20x85; 20x130; 20x200	10	250	60	250	75	1,7	1,7
Calcium silica hollow bricks acc. to EN 771-2										
Perforated limestone KS-L 8DF 12 N/mm ² $\rho \geq 1,4 \text{ kg/dm}^3$ $\geq 248 \times 240 \times 238 \text{ mm}$		M8 to M16 IG-M6 to IG-M10	16x130 20x130 20x200	5	240	50	250	50	1,4	1,0
Perforated limestone KS-L 3DF 12 N/mm ² $\rho \geq 1,4 \text{ kg/dm}^3$ $\geq 240 \times 175 \times 113 \text{ mm}$		M8 to M16 IG-M6 to IG-M10	16x85; 16x130 20x85; 20x130	5	240	60	240	120	0,63	1,0
Perforated limestone KS-L 12DF 12 N/mm ² $\rho \geq 1,4 \text{ kg/dm}^3$ $\geq 498 \times 175 \times 238 \text{ mm}$		M8 to M16 IG-M6 to IG-M10	16x130 20x130	4	500	50	500	50	1,0	1,0
Autoclaved aerated concrete acc. to EN 771-4										
AAC 2 2 N/mm ² $r \geq 0,35 \text{ kg/dm}^3$ $\geq 449 \times 240 \times 249 \text{ mm}$		M8 to M16 IG-M6 to IG-M10	without 12x80 16x85; 16x130 20x85; 20x130; 20x200	5	210	50	300	50	0,34	0,43
AAC 4 4 N/mm ² $\rho \geq 0,5 \text{ kg/dm}^3$ $\geq 449 \times 240 \times 249 \text{ mm}$		M8 to M16 IG-M6 to IG-M10	without 12x80 16x85; 16x130 20x85; 20x130; 20x200	5	210	50	300	50	0,86	1,3
AAC 6 6 N/mm ² $\rho \geq 0,6 \text{ kg/dm}^3$ $\geq 449 \times 240 \times 249 \text{ mm}$		M8 to M16 IG-M6 to IG-M10	without 12x80 16x85; 16x130 20x85; 20x130; 20x200	5	210	50	300	50	1,1	1,7
Lightweight concrete solid block acc. to EN 771-3										
VBL 2 N/mm ² $\rho \geq 0,6 \text{ kg/dm}^3$ $\geq 240 \times 300 \times 113 \text{ mm}$		M8 to M16 IG-M6 to IG-M10	without 12x80 16x85; 16x130 20x85; 20x130; 20x200	2	150	60	300	120	0,86	0,86



Naming Compressive strength Density Dimensions	Picture	Anchor rods	Perforated sleeve	T _{inst}	c _{cr}	c _{min}	s _{cr}	s _{min}	N _{rec}	V _{rec}
				[Nm]	[mm]	[mm]	[mm]	[mm]	[kN]	[kN]
Hollow light weight concrete brick acc. to EN 771-3										
HBL 3 N/mm ² ρ ≥ 1,0 kg/dm ³ ≥ 500x250x240 mm		M8 to M16 IG-M6 to IG-M10	16x85; 16x130 20x85; 20x130	2	250	50	500	50	0,34	0,57
Hollow concrete brick acc. to EN 771-2										
Perforated concrete block Bloc Creux B40 5 N/mm ² ρ ≥ 0,8 kg/dm ³ ≥ 495x195x190 mm		M8 to M16 IG-M6 to IG-M10	16x130 20x130	4	170	50	200	50	0,57	1,7
Solid clay brick acc. to EN 771-1										
Solid clay brick Mz-1DF 20 N/mm ² ρ ≥ 2,0 kg/dm ³ ≥ 240x115x55 mm		M8 to M16 IG-M6 to IG-M10	without 12x80 16x85; 16x130 20x85; 20x130; 20x200	10	250	60	250	65	2,0	2,3
Solid clay brick Mz-2DF 20 N/mm ² ρ ≥ 2,0 kg/dm ³ ≥ 240x115x113 mm		M8 to M16 IG-M6 to IG-M10	without 12x80 16x85; 16x130 20x85; 20x130; 20x200	10	250	50	250	50	2,1	2,3
Hollow clay brick acc. to EN 771-1										
Hollow clay brick HLZ 16DF 20 N/mm ² ρ ≥ 1,25 kg/dm ³ ≥ 300x240x249 mm		M8 to M16 IG-M6 to IG-M10	12x80 16x85; 16x130 20x85; 20x130; 20x200	5	300	50	300	50	0,71	2,3
Hollow clay brick BGV Thermo 10 N/mm ² ρ ≥ 0,60 kg/dm ³ ≥ 500x200x314 mm		M8 to M16 IG-M6 to IG-M10	12x80 16x85; 16x130 20x85; 20x130	2	500	120	500	120	0,26	1,0
Hollow clay brick Calibric R+ 12 N/mm ² ρ ≥ 0,6 kg/dm ³ ≥ 500x200x314 mm		M8 to M16 IG-M6 to IG-M10	16x85; 16x130 20x85; 20x130	2	500	120	500	120	0,34	1,6
Hochlochziegel Urbanbric 12 N/mm ² ρ ≥ 0,7 kg/dm ³ ≥ 560x200x274 mm		M8 to M16 IG-M6 to IG-M10	12x80 16x85; 16x130 20x85; 20x130	2	560	120	560	100	0,34	1,3
Hollow clay brick Porotherm Homebric 10 N/mm ² ρ ≥ 0,7 kg/dm ³ ≥ 500x200x299 mm		M8 to M16 IG-M6 to IG-M10	12x80 16x85; 16x130 20x85; 20x130	2	500	120	500	300	0,34	0,86



Naming Compressive strength Density Dimensions	Picture	Anchor rods	Perforated sleeve	T _{inst}	c _{cr}	c _{min}	s _{cr}	s _{min}	N _{rec}	V _{rec}
				[Nm]	[mm]	[mm]	[mm]	[mm]	[kN]	[kN]
Hollow clay brick Brique Creuse C40 12 N/mm ² ρ ≥ 0,7 kg/dm ³ ≥ 500x200x200 mm		M8 to M16 IG-M6 to IG-M10	12x80 16x85; 16x130 20x85; 20x130	2	500	120	500	100	0,34	0,43
Hollow clay brick Blocchi Leggeri 12 N/mm ² ρ ≥ 0,6 kg/dm ³ ≥ 250x120x250 mm		M8 to M16 IG-M6 to IG-M10	12x80 16x85; 16x130 20x85; 20x130	2	250	60	250	100	0,17	1,0
Hollow clay brick Doppio Uni 28 N/mm ² ρ ≥ 0,9 kg/dm ³ ≥ 250x120x120 mm		M8 to M16 IG-M6 to IG-M10	12x80 16x85; 16x130 20x85; 20x130	2	250	100	250	100	0,34	0,71
Hollow clay brick with insulation EN 771-1										
Coriso WS07 6 N/mm ² ρ ≥ 0,55 kg/dm ³ ≥ 248x365x249 mm		M8 to M16 IG-M6 bis IG-M10	12x80 16x85; 16x130 20x85; 20x130; 20x200	5	250	50	250	50	0,43	1,4
T7MW 8 N/mm ² ρ ≥ 0,59 kg/dm ³ ≥ 248x365x249 mm		M8 to M16 IG-M6 to IG-M10	12x80 16x85; 16x130 20x85; 20x130; 20x200	5	250	50	250	50	0,57	0,86
T8P 6 N/mm ² r ≥ 0,56 kg/dm ³ ≥ 248x365x249 mm		M8 to M16 IG-M6 to IG-M10	12x80 16x85; 16x130 20x85; 20x130; 20x200	4	250	50	250	50	0,43	1,3
MZ90-G 12 N/mm ² ρ ≥ 0,68 kg/dm ³ ≥ 248x365x249 mm		M8 to M16 IG-M6 to IG-M10	12x80 16x85; 16x130 20x85; 20x130; 20x200	4	250	50	250	50	0,86	1,1



4. Post-installed rebar

Installation instruction

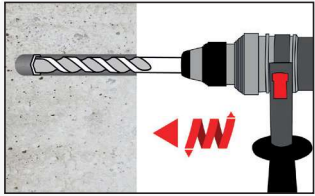
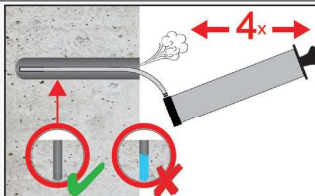
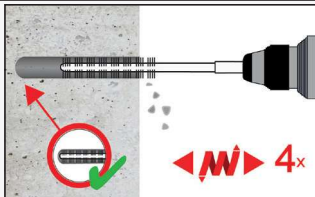
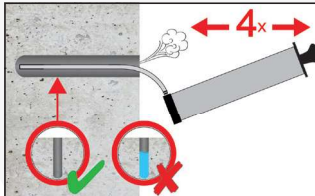
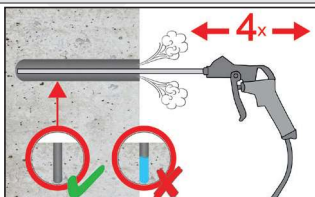
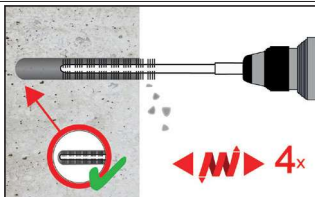
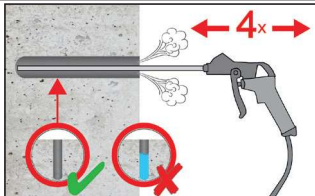
Bore hole drilling	
	<p>1a. Drill a hole into the base material to the size and embedment depth required by the selected reinforcing bar with carbide hammer drill (HD), compressed air drill (CD) or hollow drill bit.system (HDB).</p> <p>In case of aborted drill hole: the hole shall be filled with mortar.</p>
Attention! Standing water in the bore hole must be removed before cleaning.	
MAC: Cleaning for bore hole diameter $d_0 \leq 20\text{mm}$ and bore hole depth $h_0 \leq 10d_s$	
	<p>2a. Starting from the bottom or the back of the bore hole, blow the hole clean by a hand pump (see page 25) a minimum of four times:</p>
	<p>2b. Check the brush diameter (page 25). Brush the hole with an appropriate sized wire brush $> d_{b,\text{min}}$ (see page 25) a minimum of four times in a twisting motion. If the borehole ground is not reached with the brush, a brush extension must be used.</p>
	<p>2c. Finally blow the hole clean again with a hand pump (see page 25) a minimum of four times.</p>
CAC: Cleaning for all bore hole diameter and bore hole depth	
	<p>2a. Starting from the bottom or back of the bore hole, blow the hole clean with compressed air (min. 6 bar) (see page 25) a minimum of four times until return air stream is free of noticeable dust. If the bore hole ground is not reached an extension shall be used.</p>
	<p>2b. Check the brush diameter (see page 25). Brush the hole with an appropriate sized wire brush $> d_{b,\text{min}}$ (see page 25) a minimum of two times. If the borehole ground is not reached with the brush, a brush extension shall be used.</p>
	<p>2c. Finally blow the hole clean again with compressed air (min. 6 bar) (see page 25) a minimum of four times until return air stream is free of noticeable dust. If the bore hole ground is not reached an extension shall be used.</p>
<p>After cleaning, the bore hole has to be protected against re-contamination in an appropriate way, until dispensing the mortar in the bore hole. If necessary, the cleaning has to be repeated directly before dispensing the mortar. In-flowing water must not contaminate the bore hole again.</p>	



Preparation of bar and cartridge

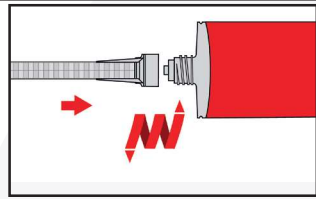

3. Attach the supplied static-mixing nozzle to the cartridge and load the cartridge into the correct dispensing tool. For every working interruption longer than the recommended working time (see page 4 - 5) as well as for new cartridges, a new static-mixer shall be used.

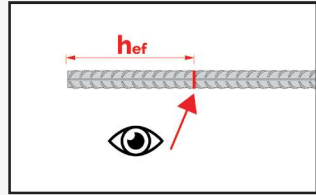

4. Prior to inserting the reinforcing bar into the filled bore hole, the position of the embedment depth shall be marked (e.g. with tape) on the reinforcing bar and insert bar in empty hole to verify hole and depth l_v (see page 24).

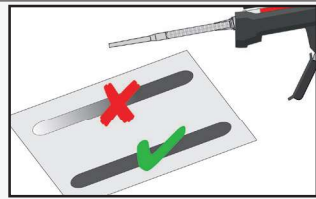

5. Prior to dispensing into the anchor hole, squeeze out separately the mortar until it shows a consistent grey colour, but a minimum of three full strokes and discard non-uniformly mixed adhesive components.

Filling the bore hole

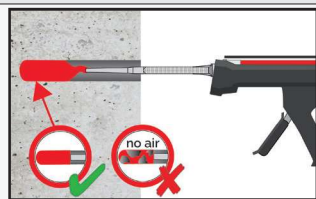

6a. Starting from the bottom or back of the cleaned anchor hole fill the hole up to approximately two-thirds with adhesive. Slowly withdraw of the static mixing nozzle as the hole is filled avoids creating air pockets. For embedment larger than 190 mm an extension nozzle shall be used.

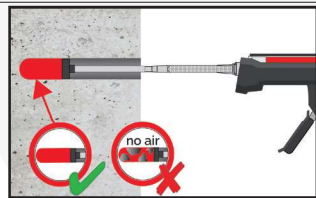

6a. For overhead and horizontal installation and bore holes deeper than 240 mm a piston plug and the appropriate mixer extension must be used.
Observe the gel-/ working times given on page 4 - 5.

Bar size-Ø	Tension anchor-Ø	Drill bit- Ø		Piston plug	Cartridge: All sizes				Cartridge: side-by-side (825 ml)		
					Hand or battery tool		Pneumatic tool		Pneumatic tool		
					$l_{v,max}$	Mixer extension	$l_{v,max}$	Mixer extension	$l_{v,max}$	Mixer extension	
[mm]	[mm]	[mm]		[-]	[cm]	[-]	[cm]	[-]	[cm]	[-]	
8		12	-	-	70	VL 10/0,75	VL 10/0,75	80	VL 10/0,75	80	
10		14	-	VS14				100		100	100
12	ZA-M12	16		VS16				100		100	120
14		18		VS18				100		100	140
16	ZA-M16	20		VS20				100		100	160
20	ZA-M20	25	26	VS25	50	VL 10/0,75	VL 10/0,75	200	VL 16/1,8	200	
22		28		VS28							
24		32		VS32							
25	ZA-M24	32		VS32							
28		35		VS35							
32		40		VS40							

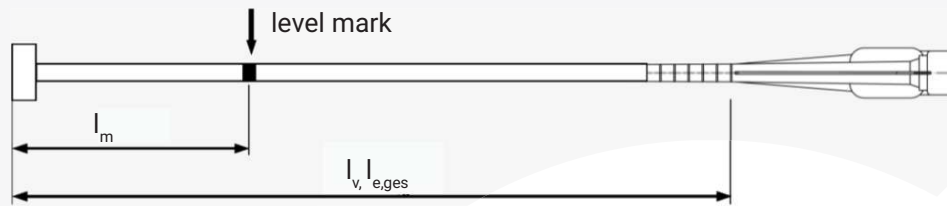

Injection tool must be marked by mortar level mark l_m and anchorage depth l_v resp. $l_{e,ges}$ with tape or marker.
 Quick estimation: $l_m = 1/3 * l_v$

Continue injection until mortar level mark l_m becomes visible.

Optimum mortar volume: $l_m = l_v$ rep. $l_{e,ges} * (1,2 * \varnothing^2 / d_0^2 * 0,2)$ [mm]

Inserting rebar	
	<p>7. Push the reinforcing bar into the anchor hole while turning slightly to ensure positive distribution of the adhesive until the embedment depth is reached.</p> <p>The bar should be free of dirt, grease, oil or other foreign material.</p>
	<p>8. Be sure that the bar is inserted in the bore hole until the embedment mark is at the concrete surface and that excess mortar is visible at the top of the hole. If these requirements are not maintained, the application has to be renewed. For overhead application the anchor rod shall be fixed (e.g. wedges).</p>
	<p>9. Observe gelling time t_{gel}. Attend that the gelling time can vary according to the base material temperature (see page 4 - 5). It is not allowed to move the bar after gelling time t_{gel} has elapsed. Allow the adhesive to cure to the specified time prior to applying any load. Do not move or load the bar until it is fully cured (attend table on page 4 - 5). After full curing time t_{cure} has elapsed, the add-on part can be installed.</p>



Cleaning and installation tools

Rec. compressed air tool hand slide valve
(min 6 bar)



Brush RBT and brush extension



Hand pump (volume 750 ml)



SDS Plus Adapter



HDB - Hollow drill bit



Ø Bar size	Ø Tension anchor	d ₀ Drill bitr	d _b Brush-Ø		d _{b,min} min. Brush-Ø
[mm]	[mm]	[mm]	[-]	[mm]	[mm]
8	-	12	RBT12	14	12,5
10	-	14	RBT14	16	14,5
12	ZA-M12	16	RBT16	18	16,5
14	-	18	RBT18	20	18,5
16	ZA-M16	20	RBT20	22	20,5
20	ZA-M20	25	RBT25	27	25,5
22	-	28	RBT28	30	28,5
24	-	32	RBT32	34	32,5
25	ZA-M24	32	RBT32	34	32,5
28	-	35	RBT35	37	35,5
32	-	40	RBT40	41,5	40,5



Design anchorage and lap length

The calculation of the design anchoring lengths of reinforcing bars, if used as end anchoring or as overlapping joint, has to consider the details and provisions of the approval ETA-09/0277 and the EN 1992-1-1:2004+AC:2010.

The design load with corresponding failure mode („pull-out failure“ or „steel failure“) were determined for selected rebar diameters and anchorage lengths. The results for end anchoring and overlapping joints are given in the tables below.

The calculations are based on following assumptions:

- Rebar BSt 500 S, $f_{yk} = 500 \text{ N/mm}^2$, Material safety factor of $\gamma_s = 1,15$
- Concrete class C20/25 and „good bond conditions“ acc. EN 1992-1-1:2004+AC:2010 considered. Rebar diameters $\leq d = 32 \text{ mm}$.
- The bond properties of the bars is considered by the coefficients:
 - $\alpha_1 = 1,0$; is for the effect of the form of the bars assuming adequate cover; 1,0 for straight rebars
 - $\alpha_2 = 1,0$; is for the effect of concrete minimum cover; has to be checked
 - $\alpha_3 = 1,0$; is for the effect of confinement by transverse reinforcement; 1,0 for no transverse reinforcement
 - $\alpha_4 = 1,0$; is for the influence of one or more welded transverse bars; 1,0 for no welded transverse reinforcement
 - $\alpha_5 = 1,0$; is for the effect of the pressure transverse; 1,0 if no transverse pressure is assumed
 - $\alpha_6 = 1,5$; is for the percentage of lapped bars relative to the total cross-section area, 1,5 due to the given situation on the construction side

All drilling methods (hammer drilling, compressed air drilling, Hollow drill bit) are considered by the amplification factor of $\alpha_{lb} = 1,0$.

End anchoring of slabs or beams (e.g. designed as simply supported)

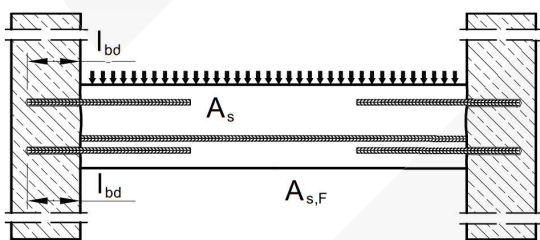

Overlapping joint for rebar connections of slabs and beams

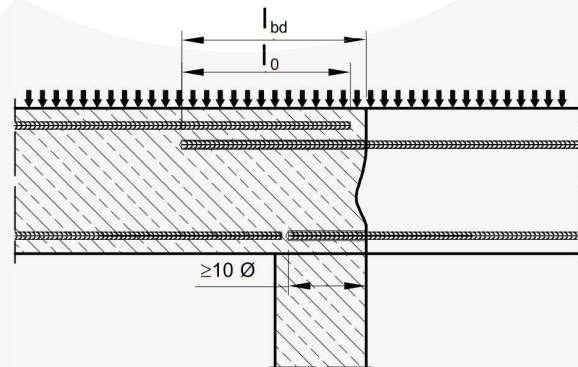



Rebar Ø8 - Ø32			End anchoring			Overlapping joint		
Concrete class C20/25 Rebar BSt 500 S; $f_{yk} = 500 \text{ N/mm}^2$ Hammer-, hollow- or compressed air drilling			$\alpha_1 = \alpha_2 = \alpha_3 = \alpha_4 = \alpha_5 = 1,0$			$\alpha_1 = \alpha_2 = \alpha_3 = \alpha_4 = \alpha_5 = 1,0$		
			$\alpha_{1b} = 1,0$			$\alpha_6 = 1,5$		
						$\alpha_{1b} = 1,0$		
d	$N_{Rd,s}$	$l_{v,max}$	l_{bd}	N_{Rd}	Volume Mortar	l_0	N_{Rd}	Volume Mortar ¹⁾
[mm]	[kN]	[mm]	[mm]	[kN]	[ml]	[mm]	[kN]	[ml]
Ø8	21,9	1000	113	6,6	9	200	7,7	15
			200	11,6	15	320	12,3	24
			290	16,8	22	440	17,0	33
			378	21,9	29	567	21,9	43
Ø10	34,1	1000	142	10,2	13	213	10,2	19
			250	18,1	23	380	18,3	34
			360	26,0	33	550	26,5	50
			473	34,1	43	709	34,1	64
Ø12	49,2	1200	170	14,8	18	255	14,8	27
			300	26,0	32	450	26,0	48
			430	37,3	45	650	37,6	69
			567	49,2	60	851	49,2	90
Ø14	66,9	1400	198	20,1	24	298	20,1	36
			350	35,4	42	530	35,7	64
			500	50,6	60	760	51,3	92
			662	66,9	80	992	66,9	120
Ø16	87,4	1600	227	26,2	31	340	26,2	46
			400	46,2	54	600	46,2	81
			580	67,1	79	860	66,3	117
			756	87,4	103	1134	87,4	154
Ø20	136,6	2000	284	41,0	60	425	41,0	90
			500	72,3	106	760	73,2	161
			720	104,0	153	1090	105,0	231
			945	136,6	200	1418	136,6	301
Ø22	165,3	2000	312	49,6	22	468	49,6	132
			550	87,4	39	830	88,0	235
			790	125,6	56	1190	126,1	336
			1040	165,3	73	1560	165,3	441
Ø24	196,7	2000	340	59,0	144	510	59,0	216
			600	104,0	253	910	105,2	384
			860	149,1	363	1310	151,4	553
			1134	196,7	479	1701	196,7	718
Ø25	213,4	2000	354	64,0	133	532	64,0	200
			630	113,8	237	950	114,4	357
			910	164,4	342	1360	163,8	511
			1181	213,4	444	1772	213,4	666
Ø28	267,7	1000	397	80,3	165	595	80,3	247
			600	121,4	249	730	98,5	303
			800	161,9	333	860	116,0	357
			1000 ²⁾	202,3	416	1000 ²⁾	134,9	416
Ø32	349,7	1000	454	104,9	246	681	104,9	369
			640	148,0	347	790	121,8	429
			820	189,6	445	900	138,7	489
			1000 ²⁾	231,2	543	1000 ²⁾	154,1	543

¹⁾ Mortar volume of the overlap joint. The mortar volume of the concrete cover c_1 , at the face of the existing reinforcing steel, was not taken into account.

²⁾ $l_{v,max}$ is limited to 1000 mm, see ETA-09/0277



The specified design load N_{Rd} (End anchoring, Overlapping joints) can be converted to further concrete classes, while maintaining the previously accepted boundary conditions and anchorage lengths l_{bd} or lap length $l_{o'}$, with the approach as follows:

$$N_{Rd,con} = \min (N_{Rd,s}; N_{Rd} * f_{bd,con} - \text{Faktor}) \text{ [kN]}$$

The conversion factor $f_{bd,con}$ can be taken from the table below:

Ø Rebar	Ø8 - Ø25 mm ZA-M12 to ZA-M24		Ø28 - Ø32 mm	
	$f_{bd,PIR}$	$f_{bd,con}$ - Faktor	$f_{bd,PIR}$	$f_{bd,con}$ - Faktor
[-]	[N/mm ²]	[-]	[N/mm ²]	[-]
C12/15	1,6	0,70	1,6	0,70
C16/20	2,0	0,87	2,0	0,87
C20/25	2,3	1,00	2,3	1,00
C25/30	2,7	1,17	2,7	1,17
C30/37	3,0	1,30	3,0	1,30
C35/45	3,4	1,48	3,4	1,48
C40/50	3,7	1,61	3,7	1,61
C45/55	4,0	1,74	3,7	1,61
C50/60	4,3	1,87	3,7	1,61



Fire resistance - Overlapping joints

The present tables are supplying the mean reduction factor $\bar{k}_{\theta(x)}$, needed for determining the design bond strength $f_{bd,fi}$ of post-installed rebar connections under fire exposure in a fire-resistance grating.

The specified mean reduction factor $\bar{k}_{\theta(x)}$ is valid for slab to slab connections (overlapping joints), where the lower surface is exposed perpendicular to fire (one side), the temperature is uniform. Therefore the bond resistance is uniform along the bond also and depends on the concrete cover and the duration of the fire.

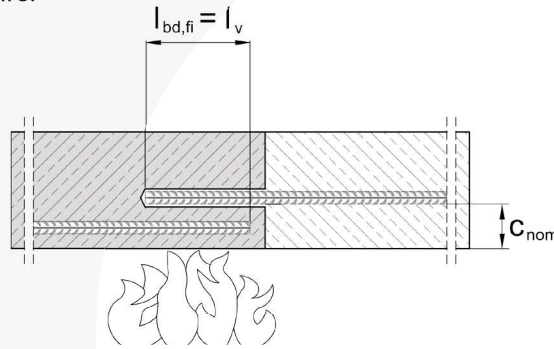

The heat development of structural members is calculated by a fire model, based on the standard uniform-temperature-time-curve (UTTC) acc. to ISO 834-1 and tries to simulate a real fire. Below the calculated heat distribution of a slab after a temperature impact of 14400 sec. (240min) for the fire-resistance grade R240.

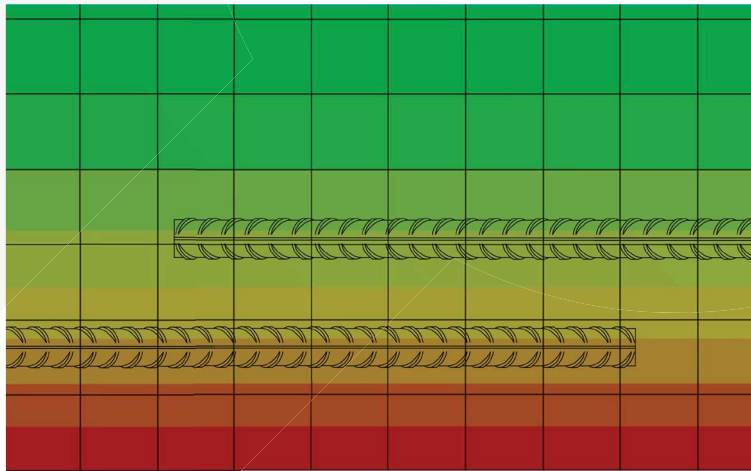

The effect of heat on the bond strength of the mortar was determined by tests and is expressed by the reduction factor $k_{b,fi}(\theta)$ given in the ETA-09/0277.



The calculation of the required design lap length l_0 shall be carried out in accordance with EN 1992-1-1:2004+AC:2010, section 8.7.3 and the provisions of the ETA-09/0277 shall be met. The design value of the bond strength $f_{bd,fi}$ under fire exposure has to be calculated by the following equation:

$$f_{bd,fi} = \bar{k}_{\Theta(x)} * f_{bd,PIR} * \gamma_c / \gamma_{M,fi} * f_{bd,fi,con} \leq f_{bd,PIR}$$

with:

- $f_{bd,fi}$ = Design value of the bond strength under fire exposure in N/mm²
- $\bar{k}_{\Theta(x)}$ = Mean reduction factor under fire exposure as a function of the temperature profile, given in the tables below
- $f_{bd,PIR}$ = Design value of the bond strength in cold condition acc. ETA-09/0277, tab. C2 depending on concrete class, rebar diameter, drilling method and bonding range acc. EN 1992-1-1 in N/mm²
- γ_c = Partial safety factor of concrete acc. EN 1992-1-1; 1,5 in absence of national regulation
- $\gamma_{M,fi}$ = Partial safety factor of fire exposure acc. EN 1992-1-2; 1,0 in absence of national regulation
- $f_{bd,fi,con}$ = Conversion factor taking into account the influence of the concrete class

The mean reduction factor $\bar{k}_{\Theta(x)}$ for slab to slab connections with rebar Ø8 - Ø32 mm and fire at 30, 60, 90, 120, 180 or 240 min is given for a concrete cover c_{nom} in the present table and valid for good bond conditions only:

Overlapping joint						
Rebar Ø8 - Ø32 mm	Mean reduction factor under fire exposure $\bar{k}_{\Theta(x)}$ ²⁾					
	Fire-resistance grading					
c_{nom} ¹⁾	R30	R60	R90	R120	R180	R240
[mm]	[-]	[-]	[-]	[-]	[-]	[-]
10	0,00	0,00	0,00	0,00	0,00	0,00
15						
20						
25						
30						
35	0,06	0,06	0,05	0,04	0,05	0,09
40	0,11					
45	0,18					
50	0,26					
55	0,36					
60	0,46	0,08	0,10	0,07	0,12	0,12
65	0,57	0,12				
70	0,66	0,16				
75	0,75	0,21				
80	0,83	0,27				
85	0,90	0,33	0,13	0,05	0,09	0,12
90	0,96	0,39	0,16	0,07		
95	1,00	0,46	0,20	0,09		
100	1,00	0,52	0,24	0,12		



Overlapping joint						
Rebar Ø8 - Ø32 mm	Mean reduction factor under fire exposure $\bar{k}_{\theta(x)}$ ²⁾					
	Fire-resistance grading					
c_{nom} ¹⁾	R30	R60	R90	R120	R180	R240
[mm]	[-]	[-]	[-]	[-]	[-]	[-]
105	1,00	0,58	0,29	0,15	0,05	0,00
110	1,00	0,65	0,34	0,18	0,06	
115	1,00	0,71	0,39	0,22	0,08	
120	1,00	0,78	0,45	0,26	0,09	0,04
125	1,00	0,83	0,50	0,30	0,12	0,05
130	1,00	0,89	0,56	0,34	0,14	0,06
135	1,00	0,94	0,61	0,39	0,17	0,08
140	1,00	0,99	0,66	0,44	0,19	0,09
145	1,00	1,00	0,72	0,49	0,23	0,11
150	1,00	1,00	0,77	0,54	0,26	0,13
155	1,00	1,00	0,82	0,58	0,29	0,15
160	1,00	1,00	0,87	0,63	0,33	0,17
165	1,00	1,00	0,91	0,69	0,37	0,20
170	1,00	1,00	0,96	0,73	0,40	0,23
175	1,00	1,00	0,99	0,77	0,45	0,25
180	1,00	1,00	1,00	0,80	0,48	0,28

¹⁾ c_{nom} = concrete cover
²⁾ $\bar{k}_{\theta(x)}$ = Mean reduction factor over the embedment depth of the rebar as a function of the temperature profile

Intermediate values of $\bar{k}_{\theta(x)}$ may be interpolated linearly. Extrapolation is not permitted.

The bond strength $f_{bd,PIR}$ depends on the concrete class and rebar diameter as well as the corresponding conversion factor $f_{bd,fi,con}$ and can be found in the following table:

Concrete class	Ø-Rebar	$f_{bd,PIR}$ (all drilling methods)	$f_{bd,fi,con}$ - Factor
[-]	[mm]	[N/mm ²]	[-]
C12/15	all	1,6	1,438
C16/20	all	2,0	1,150
C20/25	all	2,3	1,000
C25/30	all	2,7	0,852
C30/37	all	3,0	0,767
C35/45	all	3,4	0,676
C40/50	all	3,7	0,622
C45/50	≤ Ø25 (Ø28;Ø32)	4,0 (3,7)	0,575 (0,622)
C50/60	≤ Ø25 (Ø28;Ø32)	4,3 (3,7)	0,535 (0,622)

The given values does not deal with the mechanical design at ambient temperature, these shall be done in addition and related to ETA-09/0277.

Post-installed rebar connections shall be designed in ambient temperature conditions before being designed in fire conditions.

The partial safety factor for actions can be assumed to be $\gamma_F = 1,0$ for determining recommended loads.



Fire resistance - Beam/wall or column/slab

The present table is supplying the mean reduction factor $\bar{k}_{\sigma(x)}$, needed for determining the design bond strength $f_{bd,fi}$ of post-installed rebar connections under fire exposure in a fire-resistance rating.

The mean reduction factor $\bar{k}_{\sigma(x)}$ is valid for beam to wall or column to slab connections, where the rebar is bonded inside the wall or slab, there is a temperature gradient in the thickness of the wall respectively slab if the beam (three sides) or column is exposed to fire (four sides).

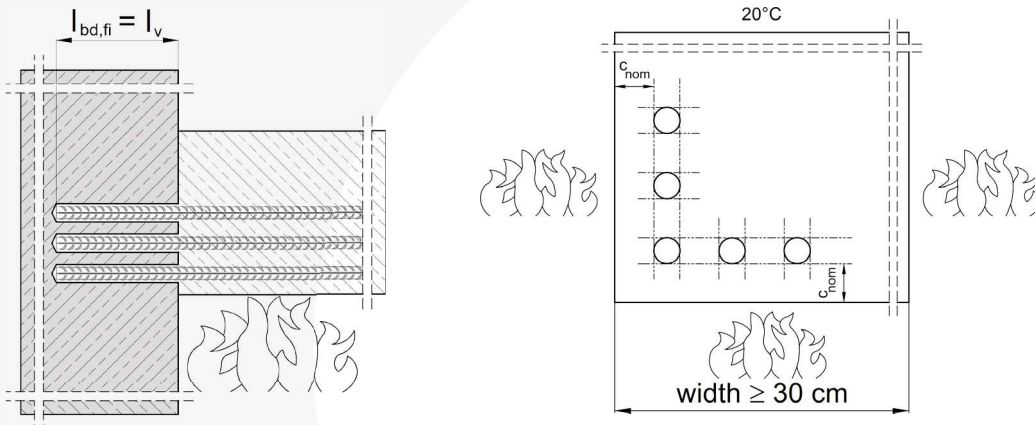

The temperature along the bonding interface is not uniform and depends on the fire duration, the anchoring length and the concrete cover of the rebar inside the beam (which acts as a protection against thermal exposure). Therefore, the temperature profiles along the bond are determined for each fire duration, for each bonded length and for the concrete covers inside the beam of $c_{nom} = 10, 20, 30$ and 40 mm.

The given mean reduction factor $\bar{k}_{\sigma(x)}$ is a mean value as a function of the temperature profile along the bonding length.

The calculated model of the fire is based on the standard uniform-temperature-time-curve (UTTC) acc. to ISO 834-1 and tries to simulate the heat development of structural members at a real fire. Below the calculated heat distribution of a beam / column and wall / slab after a temperature impact of 14400 sec. (240min) for the fire-resistance grade R240.

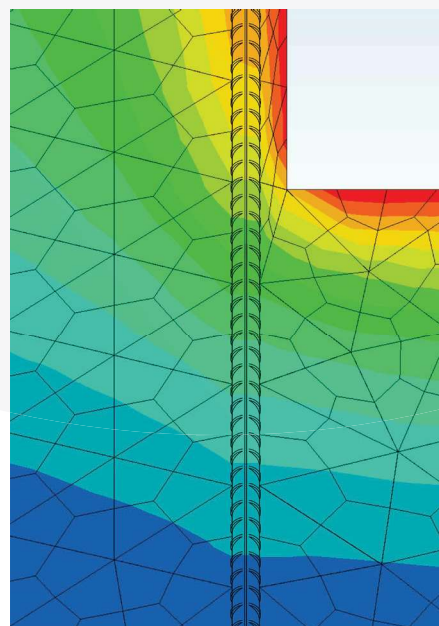
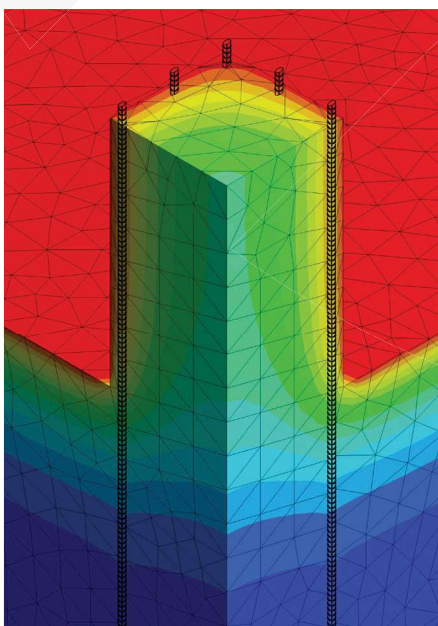



The fire model determines the heat distribution for rebars at the component corner (2 sides flamed) and at the component edge (1 side flamed).



The effect of heat on the bond strength of the mortar was determined by tests and is expressed by the reduction factor $k_{b,fi}(\theta)$ given in the ETA-09/0277.

The calculation of the required design lap length l_0 shall be carried out in accordance with EN 1992-1-1:2004+AC:2010, section 8.7.3 and the provisions of the ETA-09/0277 shall be met.

The design value of the bond strength $f_{bd,fi}$ under fire exposure has to be calculated by the following equation:

$$f_{bd,fi} = \bar{k}_{\theta(x)} * f_{bd,PIR} * \gamma_c / \gamma_{M,fi} * f_{bd,fi,con} \leq f_{bd,PIR}$$

with:

- $f_{bd,fi}$ = Design value of the bond strength under fire exposure in N/mm²
- $\bar{k}_{\theta(x)}$ = Mean reduction factor under fire exposure as a function of the temperature profile, given in the tables below
- $f_{bd,PIR}$ = Design value of the bond strength in cold condition acc. ETA-09/0277, tab. C2 depending on concrete class, rebar diameter, drilling method and bonding range acc. EN 1992-1-1 in N/mm²
- γ_c = Partial safety factor of concrete acc. EN 1992-1-1; 1,5 in absence of national regulation
- $\gamma_{M,fi}$ = Partial safety factor of fire exposure acc. EN 1992-1-2; 1,0 in absence of national regulation
- $f_{bd,fi,con}$ = Conversion factor taking into account the influence of the concrete class

The mean reduction factor $\bar{k}_{\theta(x)}$ for e.g. beam on wall or column on slab applications for concrete covers of $c_{nom} = 10, 20, 30$ and 40 mm with the corresponding diameter of the rebar and fire-resistance grading at 30, 60, 90, 120, 180 or 240 min is given for a rebar at the edge (1 side flamed) or at the corner (2 sides flamed) in the following tables and valid for good bond conditions:



Endanchoring - Mean reduction factor under fire exposure $\bar{k}_{\theta(x)}$ ³⁾														
$c_{nom} = 10$ mm ¹⁾	Rebar at the edge (1 side flamed)						Rebar at the corner (2 sides flamed)							
Rebar Ø8 - Ø20	Fire-resistance grading						Fire-resistance grading							
l_v ²⁾	R30	R60	R90	R120	R180	R240	R30	R60	R90	R120	R180	R240		
[mm]	[-]	[-]	[-]	[-]	[-]	[-]	[-]	[-]	[-]	[-]	[-]	[-]		
80	0,32	0,09	0,03	0,01	0,00	0,00	0,18	0,04	0,01	0,00	0,00	0,00		
90	0,38	0,12	0,05	0,02			0,23	0,06	0,02					
100	0,44	0,15	0,07	0,03			0,01	0,29	0,09				0,03	0,01
110	0,49	0,19	0,10	0,05			0,01	0,35	0,12				0,05	0,02
120	0,54	0,24	0,13	0,07	0,02	0,01	0,41	0,15	0,07	0,04	0,01	0,00		
130	0,57	0,29	0,16	0,09	0,03	0,01	0,45	0,19	0,10	0,05	0,02			
140	0,60	0,34	0,20	0,12	0,05	0,02	0,49	0,23	0,13	0,07	0,03		0,01	
150	0,63	0,38	0,23	0,15	0,06	0,03	0,53	0,27	0,16	0,10	0,04		0,02	
160	0,65	0,42	0,28	0,18	0,08	0,04	0,56	0,31	0,20	0,12	0,05		0,02	
170	0,67	0,45	0,32	0,21	0,10	0,05	0,58	0,35	0,24	0,15	0,07		0,03	
180	0,69	0,48	0,35	0,24	0,12	0,06	0,60	0,39	0,28	0,19	0,09		0,04	
190	0,71	0,51	0,39	0,28	0,14	0,08	0,63	0,42	0,32	0,22	0,11		0,06	
200	0,72	0,54	0,42	0,32	0,17	0,09	0,64	0,45	0,36	0,26	0,13		0,07	
210	0,73	0,56	0,45	0,35	0,19	0,11	0,66	0,47	0,39	0,29	0,16		0,09	
220	0,75	0,58	0,47	0,38	0,22	0,13	0,68	0,50	0,41	0,32	0,18	0,11		
230	0,76	0,60	0,49	0,40	0,25	0,15	0,69	0,52	0,44	0,35	0,21	0,13		
240	0,77	0,61	0,52	0,43	0,28	0,17	0,70	0,54	0,46	0,38	0,24	0,15		
250	0,78	0,63	0,54	0,45	0,30	0,20	0,72	0,56	0,48	0,40	0,27	0,17		
260	0,79	0,64	0,55	0,47	0,33	0,22	0,73	0,57	0,50	0,43	0,29	0,19		
270	0,79	0,66	0,57	0,49	0,36	0,24	0,74	0,59	0,52	0,45	0,32	0,21		
280	0,80	0,67	0,58	0,51	0,38	0,26	0,75	0,60	0,54	0,47	0,34	0,24		
290	0,81	0,68	0,60	0,53	0,40	0,29	0,75	0,62	0,56	0,49	0,37	0,26		
300	0,81	0,69	0,61	0,54	0,42	0,31	0,76	0,63	0,57	0,50	0,39	0,28		
310	0,82	0,70	0,63	0,56	0,44	0,33	0,77	0,64	0,58	0,52	0,41	0,31		
320	0,83	0,71	0,64	0,57	0,46	0,35	0,78	0,65	0,60	0,53	0,43	0,33		
350	0,84	0,73	0,67	0,61	0,50	0,41	0,80	0,68	0,63	0,57	0,47	0,39		
400	0,86	0,77	0,71	0,66	0,56	0,48	0,82	0,72	0,68	0,63	0,54	0,46		
450	0,88	0,79	0,74	0,70	0,61	0,54	0,84	0,75	0,71	0,67	0,59	0,52		
500	0,89	0,81	0,77	0,73	0,65	0,59	0,86	0,78	0,74	0,70	0,63	0,57		
550	0,90	0,83	0,79	0,75	0,68	0,62	0,87	0,80	0,77	0,73	0,67	0,61		
600	0,91	0,85	0,81	0,77	0,71	0,66	0,88	0,82	0,79	0,75	0,69	0,64		
700	0,92	0,87	0,83	0,80	0,75	0,70	0,90	0,84	0,82	0,79	0,74	0,69		
800	0,93	0,88	0,85	0,83	0,78	0,74	0,91	0,86	0,84	0,81	0,77	0,73		
900	0,94	0,90	0,87	0,85	0,81	0,77	0,92	0,88	0,86	0,83	0,80	0,76		
1000	0,94	0,91	0,88	0,86	0,83	0,79	0,93	0,89	0,87	0,85	0,82	0,79		

¹⁾ c_{nom} = concrete cover

²⁾ l_v = embedment length of the bar in the concrete

³⁾ $\bar{k}_{\theta(x)}$ = Mean reduction factor over the embedment depth of the rebar as a function of the temperature profile

Intermediate values of $\bar{k}_{\theta(x)}$ may be interpolated linearly. Extrapolation is not permitted.



Endanchoring - Mean reduction factor under fire exposure $\bar{k}_{\theta(x)}$ ³⁾												
$c_{nom} = 20$ mm ¹⁾	Rebar at the edge (1 side flamed)						Rebar at the corner (2 sides flamed)					
Rebar Ø8 - Ø20	Fire-resistance grading						Fire-resistance grading					
l_v ²⁾	R30	R60	R90	R120	R180	R240	R30	R60	R90	R120	R180	R240
[mm]	[-]	[-]	[-]	[-]	[-]	[-]	[-]	[-]	[-]	[-]	[-]	[-]
80	0,44	0,14	0,05	0,02	0,00	0,00	0,23	0,05	0,01	0,00	0,00	0,00
90	0,49	0,17	0,07	0,03			0,28	0,07	0,02			
100	0,53	0,20	0,09	0,04	0,01	0,00	0,32	0,09	0,03	0,01	0,00	0,00
110	0,57	0,23	0,11	0,05	0,01		0,36	0,11	0,04	0,02		
120	0,61	0,27	0,13	0,07	0,02		0,41	0,14	0,06	0,03		
130	0,64	0,30	0,15	0,08	0,03	0,01	0,45	0,17	0,08	0,04	0,01	0,01
140	0,66	0,34	0,18	0,10	0,03	0,01	0,49	0,20	0,10	0,05	0,02	
150	0,69	0,37	0,21	0,12	0,05	0,02	0,53	0,24	0,12	0,07	0,02	0,01
160	0,70	0,41	0,24	0,14	0,06	0,02	0,56	0,27	0,15	0,09	0,03	0,01
170	0,72	0,44	0,27	0,17	0,07	0,03	0,58	0,31	0,17	0,11	0,04	0,02
180	0,74	0,47	0,30	0,19	0,08	0,04	0,61	0,35	0,20	0,13	0,06	0,03
190	0,75	0,50	0,33	0,22	0,10	0,05	0,63	0,38	0,23	0,15	0,07	0,03
200	0,76	0,53	0,36	0,24	0,12	0,06	0,65	0,41	0,26	0,17	0,08	0,04
210	0,78	0,55	0,39	0,27	0,14	0,07	0,66	0,44	0,30	0,20	0,10	0,05
220	0,79	0,57	0,42	0,30	0,16	0,09	0,68	0,46	0,33	0,23	0,12	0,07
230	0,79	0,59	0,44	0,32	0,18	0,10	0,69	0,49	0,36	0,26	0,14	0,08
240	0,80	0,60	0,46	0,35	0,20	0,12	0,70	0,51	0,38	0,28	0,16	0,10
250	0,81	0,62	0,49	0,38	0,22	0,13	0,72	0,53	0,41	0,31	0,18	0,11
260	0,82	0,64	0,51	0,40	0,24	0,15	0,73	0,55	0,43	0,34	0,20	0,13
270	0,83	0,65	0,52	0,42	0,27	0,17	0,74	0,56	0,45	0,36	0,23	0,15
280	0,83	0,66	0,54	0,44	0,29	0,19	0,75	0,58	0,47	0,39	0,25	0,17
290	0,84	0,67	0,56	0,46	0,31	0,21	0,76	0,59	0,49	0,41	0,28	0,19
300	0,84	0,68	0,57	0,48	0,34	0,23	0,76	0,61	0,51	0,43	0,30	0,21
310	0,85	0,69	0,59	0,50	0,36	0,25	0,77	0,62	0,52	0,44	0,32	0,23
320	0,85	0,70	0,60	0,51	0,38	0,27	0,78	0,63	0,54	0,46	0,34	0,25
350	0,87	0,73	0,63	0,56	0,43	0,33	0,80	0,66	0,58	0,51	0,40	0,31
400	0,88	0,76	0,68	0,61	0,50	0,41	0,82	0,71	0,63	0,57	0,47	0,40
500	0,91	0,81	0,74	0,69	0,60	0,53	0,86	0,76	0,70	0,66	0,58	0,52
600	0,92	0,84	0,79	0,74	0,67	0,61	0,88	0,80	0,75	0,71	0,65	0,60
700	0,93	0,86	0,82	0,78	0,72	0,67	0,90	0,83	0,79	0,75	0,70	0,65
800	0,94	0,88	0,84	0,81	0,75	0,71	0,91	0,85	0,81	0,78	0,74	0,70
900	0,95	0,89	0,86	0,83	0,78	0,74	0,92	0,87	0,84	0,81	0,77	0,73
1000	0,95	0,91	0,87	0,84	0,80	0,77	0,93	0,88	0,85	0,83	0,79	0,76
1500	0,97	0,94	0,91	0,90	0,87	0,84	0,95	0,92	0,90	0,89	0,86	0,84
2000	0,98	0,95	0,94	0,92	0,90	0,88	0,96	0,94	0,93	0,91	0,89	0,88

¹⁾ c_{nom} = concrete cover

²⁾ l_v = embedment length of the bar in the concrete

³⁾ $\bar{k}_{\theta(x)}$ = Mean reduction factor over the embedment depth of the rebar as a function of the temperature profile

Intermediate values of $\bar{k}_{\theta(x)}$ may be interpolated linearly. Extrapolation is not permitted.



Endanchoring - Mean reduction factor under fire exposure $\bar{k}_{\theta(x)}$ ³⁾												
$c_{nom} = 30$ mm ¹⁾	Rebar at the edge (1 side flamed)						Rebar at the corner (2 sides flamed)					
Rebar Ø8 - Ø28	Fire-resistance grading						Fire-resistance grading					
l_v ²⁾	R30	R60	R90	R120	R180	R240	R30	R60	R90	R120	R180	R240
[mm]	[-]	[-]	[-]	[-]	[-]	[-]	[-]	[-]	[-]	[-]	[-]	[-]
80	0,64	0,24	0,10	0,04	0,00	0,00	0,40	0,09	0,03	0,01	0,00	0,00
90	0,68	0,27	0,11	0,05			0,44	0,11	0,04	0,01		
100	0,71	0,29	0,13	0,06	0,01	0,00	0,48	0,14	0,05	0,02	0,00	0,00
110	0,74	0,32	0,15	0,07	0,01		0,51	0,16	0,06	0,03		
120	0,76	0,35	0,17	0,08	0,02	0,01	0,55	0,19	0,08	0,04	0,01	0,00
130	0,78	0,38	0,19	0,10	0,03		0,59	0,22	0,10	0,05	0,01	
140	0,79	0,41	0,21	0,12	0,04	0,01	0,62	0,24	0,11	0,06	0,02	0,01
150	0,81	0,44	0,24	0,13	0,05	0,01	0,64	0,27	0,13	0,07	0,02	
160	0,82	0,47	0,26	0,15	0,05	0,02	0,66	0,30	0,16	0,09	0,03	0,01
170	0,83	0,50	0,29	0,17	0,07	0,03	0,68	0,34	0,18	0,10	0,04	0,02
180	0,84	0,53	0,31	0,19	0,08	0,03	0,70	0,37	0,20	0,12	0,05	0,02
190	0,85	0,55	0,34	0,21	0,09	0,04	0,72	0,40	0,23	0,14	0,06	0,03
200	0,85	0,57	0,36	0,23	0,10	0,05	0,73	0,43	0,26	0,16	0,07	0,04
210	0,86	0,59	0,39	0,26	0,12	0,06	0,74	0,46	0,28	0,18	0,09	0,04
220	0,87	0,61	0,42	0,28	0,14	0,07	0,76	0,48	0,31	0,21	0,10	0,05
230	0,87	0,63	0,44	0,30	0,15	0,08	0,77	0,50	0,34	0,23	0,12	0,06
240	0,88	0,64	0,46	0,33	0,17	0,09	0,78	0,52	0,36	0,25	0,13	0,08
250	0,88	0,66	0,49	0,35	0,19	0,11	0,78	0,54	0,39	0,28	0,15	0,09
260	0,89	0,67	0,51	0,37	0,21	0,12	0,79	0,56	0,41	0,30	0,17	0,10
270	0,89	0,68	0,52	0,40	0,23	0,13	0,80	0,58	0,43	0,33	0,19	0,12
280	0,90	0,69	0,54	0,42	0,25	0,15	0,81	0,59	0,46	0,35	0,21	0,13
290	0,90	0,71	0,56	0,44	0,27	0,17	0,81	0,61	0,47	0,37	0,23	0,15
300	0,90	0,72	0,57	0,46	0,29	0,18	0,82	0,62	0,49	0,40	0,25	0,16
310	0,91	0,72	0,59	0,48	0,31	0,20	0,83	0,63	0,51	0,42	0,27	0,18
320	0,91	0,73	0,60	0,49	0,33	0,22	0,83	0,64	0,52	0,43	0,29	0,20
350	0,92	0,76	0,63	0,54	0,38	0,27	0,85	0,67	0,56	0,48	0,35	0,25
400	0,93	0,79	0,68	0,59	0,46	0,36	0,87	0,71	0,62	0,55	0,44	0,35
500	0,94	0,83	0,74	0,67	0,57	0,49	0,89	0,77	0,69	0,64	0,55	0,48
600	0,95	0,86	0,79	0,73	0,64	0,57	0,91	0,81	0,75	0,70	0,62	0,56
700	0,96	0,88	0,82	0,77	0,69	0,63	0,92	0,84	0,78	0,74	0,68	0,63
800	0,96	0,89	0,84	0,80	0,73	0,68	0,93	0,86	0,81	0,77	0,72	0,67
900	0,97	0,91	0,86	0,82	0,76	0,71	0,94	0,87	0,83	0,80	0,75	0,71
1000	0,97	0,91	0,87	0,84	0,78	0,74	0,95	0,89	0,85	0,82	0,77	0,74
1500	0,98	0,94	0,91	0,89	0,86	0,83	0,96	0,92	0,90	0,88	0,85	0,83
2000	0,99	0,96	0,94	0,92	0,89	0,87	0,97	0,94	0,92	0,91	0,89	0,87

¹⁾ c_{nom} = concrete cover

²⁾ l_v = embedment length of the bar in the concrete

³⁾ $\bar{k}_{\theta(x)}$ = Mean reduction factor over the embedment depth of the rebar as a function of the temperature profile

Intermediate values of $\bar{k}_{\theta(x)}$ may be interpolated linearly. Extrapolation is not permitted.



Endanchoring - Mean reduction factor under fire exposure $\bar{k}_{\theta(x)}$ ³⁾												
$c_{nom} = 40$ mm ¹⁾	Rebar at the edge (1 side flamed)						Rebar at the corner (2 sides flamed)					
Rebar Ø8 - Ø40	Fire-resistance grading						Fire-resistance grading					
l_v ²⁾	R30	R60	R90	R120	R180	R240	R30	R60	R90	R120	R180	R240
[mm]	[-]	[-]	[-]	[-]	[-]	[-]	[-]	[-]	[-]	[-]	[-]	[-]
80	0,86	0,36	0,16	0,07	0,00	0,00	0,64	0,19	0,07	0,02	0,00	0,00
90	0,87	0,39	0,17	0,08	0,01		0,67	0,22	0,08	0,03		
100	0,89	0,41	0,19	0,09	0,01		0,70	0,24	0,09	0,04		
110	0,90	0,43	0,21	0,10	0,02		0,72	0,26	0,11	0,05		
120	0,91	0,46	0,23	0,11	0,03		0,75	0,29	0,12	0,06		
130	0,91	0,48	0,24	0,13	0,03		0,77	0,31	0,14	0,07		
140	0,92	0,50	0,26	0,14	0,04	0,01	0,78	0,34	0,16	0,08	0,02	0,01
150	0,92	0,53	0,28	0,15	0,05	0,01	0,80	0,36	0,17	0,09	0,03	
160	0,93	0,55	0,30	0,17	0,05	0,02	0,81	0,39	0,19	0,10	0,03	
170	0,93	0,58	0,32	0,18	0,06	0,02	0,82	0,41	0,21	0,12	0,04	
180	0,94	0,60	0,34	0,20	0,07	0,03	0,83	0,44	0,24	0,14	0,05	
190	0,94	0,62	0,36	0,22	0,08	0,03	0,84	0,47	0,26	0,15	0,06	
200	0,94	0,64	0,39	0,24	0,09	0,04	0,85	0,49	0,28	0,17	0,07	0,03
210	0,95	0,66	0,41	0,25	0,10	0,05	0,86	0,52	0,30	0,19	0,08	0,04
220	0,95	0,67	0,43	0,27	0,12	0,05	0,86	0,54	0,33	0,21	0,09	0,04
230	0,95	0,69	0,45	0,29	0,13	0,06	0,87	0,56	0,35	0,23	0,10	0,05
240	0,95	0,70	0,47	0,31	0,14	0,07	0,87	0,58	0,37	0,25	0,12	0,06
250	0,95	0,71	0,49	0,33	0,16	0,08	0,88	0,59	0,39	0,27	0,13	0,07
260	0,96	0,72	0,51	0,35	0,17	0,09	0,88	0,61	0,42	0,29	0,15	0,08
270	0,96	0,73	0,53	0,37	0,18	0,10	0,89	0,62	0,44	0,31	0,16	0,09
280	0,96	0,74	0,55	0,39	0,20	0,11	0,89	0,64	0,46	0,33	0,18	0,10
290	0,96	0,75	0,56	0,41	0,22	0,12	0,90	0,65	0,48	0,35	0,19	0,11
300	0,96	0,76	0,58	0,43	0,23	0,13	0,90	0,66	0,50	0,37	0,21	0,13
310	0,96	0,77	0,59	0,44	0,25	0,15	0,90	0,67	0,51	0,39	0,23	0,14
320	0,96	0,77	0,60	0,46	0,26	0,16	0,90	0,68	0,53	0,41	0,24	0,15
350	0,97	0,79	0,64	0,51	0,31	0,20	0,91	0,71	0,57	0,46	0,30	0,19
400	0,97	0,82	0,68	0,57	0,39	0,27	0,92	0,75	0,62	0,53	0,38	0,27
450	0,97	0,84	0,72	0,62	0,46	0,34	0,93	0,77	0,66	0,58	0,45	0,34
500	0,98	0,86	0,75	0,66	0,52	0,41	0,94	0,80	0,70	0,62	0,50	0,41
550	0,98	0,87	0,77	0,69	0,56	0,46	0,94	0,82	0,72	0,66	0,55	0,46
600	0,98	0,88	0,79	0,71	0,60	0,51	0,95	0,83	0,75	0,68	0,59	0,51
700	0,98	0,90	0,82	0,75	0,65	0,58	0,96	0,86	0,78	0,73	0,65	0,58
800	0,99	0,91	0,84	0,78	0,70	0,63	0,96	0,87	0,81	0,76	0,69	0,63
900	0,99	0,92	0,86	0,81	0,73	0,67	0,97	0,89	0,83	0,79	0,72	0,67
1000	0,99	0,93	0,87	0,83	0,76	0,70	0,97	0,90	0,85	0,81	0,75	0,70

¹⁾ c_{nom} = concrete cover

²⁾ l_v = embedment length of the bar in the concrete

³⁾ $\bar{k}_{\theta(x)}$ = Mean reduction factor over the embedment depth of the rebar as a function of the temperature profile

Intermediate values of $\bar{k}_{\theta(x)}$ may be interpolated linearly. Extrapolation is not permitted.



The bond strength $f_{bd,PIR}$ depends on the concrete class and rebar diameter as well as on the corresponding conversion factor $f_{bd,fi,con}$ and can be found for rebar at the corner and the edge in the following table:

Concrete class [-]	Ø-Rebar [mm]	$f_{bd,PIR}$ [N/mm ²]	$f_{bd,fi,con}$ - Factor [-]
C12/15	all	1,6	1,438
C16/20	all	2,0	1,150
C20/25	all	2,3	1,000
C25/30	all	2,7	0,852
C30/37	all	3,0	0,767
C35/45	all	3,4	0,676
C40/50	all	3,7	0,622
C45/50	≤ Ø25 (Ø28;Ø32)	4,0 (3,7)	0,575 (0,622)
C50/60	≤ Ø25 (Ø28;Ø32)	4,3 (3,7)	0,535 (0,622)

The given values does not deal with the mechanical design at ambient temperature, these shall be done in addition and related to ETA-09/0277.

Post-installed rebar connections shall be designed in ambient temperature conditions before being designed in fire conditions.

The bond resistance $f_{bd,fi}$ shall not be applied for beam to beam connections.

The partial safety factor for actions can be assumed to be $\gamma_F = 1.0$ for determining recommended loads.



5. Chemical resistance

Chemical Agent	Concentration	Resistant	Not resistant
Accumulator acid		x	
Acetic acid	10%	x	
Acetic acid	40%		x
Laitance			x
Acetone	5%		x
Acetone	10%		x
Acetone	100%		x
Ammonia, aqueous solution	5%	x	
Ammonia, aqueous solution	32%		x
Aniline	100%	x	
Beer	100%	x	
Chlorine	All		x
Benzol	100%		x
Boric Acid, aqueous solution		x	
Calcium carbonate, suspended in water	All	x	
Calcium chloride, suspended in water		x	
Calcium hydroxide, suspended in water		x	
Chlorinated lime (Calcium hypochlorite)	10%		x
Carbon tetrachloride	100%	x	
Caustic soda solution	10%	x	
Caustic soda solution	40%		x
Citric acid	10%		x
Citric acid	50%		x
Citric acid	All	x	
Chlorine water, swimming pool	All	x	
Demineralized water	All		x
Diesel oil	100%	x	
Ethyl alcohol, aqueous solution	100%		x
Ethyl alcohol, aqueous solution	50%		x
Formic acid	10%		x
Formic acid	30%		x
Formic acid	100%		x
Formaldehyde, aqueous solution	20%		x
Formaldehyde, aqueous solution	30%	x	
Freon		x	
Fuel Oil		x	
Gasoline (premium grade)	100%	x	
Glycol (Ethylene glycol)		x	
Hydraulic fluid	Conc.	x	
Hydrochloric acid (Muriatic Acid)	Conc.		x
Hydrogen peroxide	10%		x
Hydrogen peroxide	30%		x
Isopropyl alcohol	100%		x
Lactic acid	10%		x
Lactic acid	All	x	
Linseed oil	100%	x	
Lubricating oil	100%	x	
Magnesium chloride, aqueous solution	All	x	
Methanol	100%		x
Standard benzine		x	
Motor oil (SAE 20 W-50)	100%	x	
Nitric acid	10%		x
Oleic acid	100%	x	
Perchloroethylene	100%	x	
Petroleum	100%	x	
Phenol, aqueous solution	8%		x

Results shown in the table are applicable to brief periods of chemical contact with full cured adhesive (e.g. temporary contact with adhesive during a spill).



Chemical Agent	Concentration	Resistant	Not resistant
Benzyl alcohol	100%		x
Phosphoric acid	85%	x	
Phosphoric acid	10%	x	
Potash lye (Potassium hydroxide)	10%	x	
Potash lye (Potassium hydroxide)	40%		x
Potassium carbonate, aqueous solution	All	x	
Potassium chlorite, aqueous solution	All	x	
Potassium nitrate, aqueous solution	All	x	
Sea water, salty	All	x	
Sodium carbonate	All	x	
Sodium chloride, aqueous solution	All	x	
Sodium phosphate, aqueous solution	All	x	
Sodium silicate	All	x	
Sulfuric acid	10%	x	
Sulfuric acid	30%		x
Sulfuric acid	70%		x
Tartaric acid	All	x	
Tetrachloroethylene	100%	x	
Toluene			x
Trichloroethylene	100%		x
Turpentine	100%	x	

Results shown in the table are applicable to brief periods of chemical contact with full cured adhesive (e.g. temporary contact with adhesive during a spill).